

stowa

ATLANTIS
**RIO
NED**
STAD · WATER · LEVEN

Vlakwa
VLAAMSE KENNISCENTRUM WATER
FLANDERS KNOWLEDGE CENTER WATER

 **vito**

KENNISEVENT NIEUWE SANITATIE

Een samenwerking over de grenzen heen...

28 November 2019 – Bovendonk, Hoeven (NL)

Afvalwater tot drinkwater



Van afvalwater naar drinkwater
Van zwartwater tot tafelwater
NEREUS technologie, van grijs
afvalwater tot drinkwater



Van afvalwater naar drink(baar)water

Ton Koekkoek
Ton van Hecke
AkaNova / D2D



Hoeveel water gebruik jij per dag in liters?



Wat doen voor meer hergebruik

- Afvalwater minimaal geschikt maken voor toiletspoeling, de was, de schoonmaak en de tuin.
- Circa 50% reductie van het waterverbruik mogelijk
- Voor consumptie wordt 1,5 liter gebruikt

Hoe te realiseren

- Sensortechniek voor een betere monitoring
- Optimalisering van de zuiveringsinstallatie
→ betere waterkwaliteit



Voorbeeld project

Waterlab Flevoland

Met als doelstelling:

- lokale zuiveringssystemen doelmatig, autonoom en circulair maken
- betaalbare en duurzame systemen die bijdragen aan een goede ecologie en gezonde leefomgeving

Streefwaarden van Waterlab

Chemical parameters	Unit	Target*	Class 3b
P-total	mg/l	< 0,2	< 3
N-total	mg/l	< 4.5	< 30
NH4 (ammonium)	mg/l	< 2	< 2
BOD	mg/l	< 5	< 20
COD	mg/l	< 50	< 100
Undissolved particles	mg/l	< 30	< 30
E.coli (indicator) or total pathogenes	#/ml	< 1800	
Micro's (heavy metals)	µg/l		
Micro's (pharmaceuticals)	µg/l		
BTEX (benthene etc)	µg/l		
pH (related to waterbody)		6 - 9	

* Target is mean from Apr - Sep. Particular samples may have a maximum of twice the value.



Streefwaarden van Waterlab

Chemical parameters	Unit	Target*	Expected
P-total	mg/l	< 0,2	< 0,2
N-total	mg/l	< 4.5	< 4.5
NH4 (ammonium)	mg/l	< 2	< 2
BOD	mg/l	< 5	< 2
COD	mg/l	< 50	< 50
Undissolved particles	mg/l	< 30	< 30
E.coli (indicator) or total pathogenes	#/ml	< 1800	0
Micro's (heavy metals)	µg/l		reduced
Micro's (pharmaceuticals)	µg/l		reduced
BTEX (benthene etc)	µg/l		reduced
pH (related to waterbody)		6 - 9	6,5 - 8

* Target is mean from Apr - Sep. Particular samples may have a maximum of twice the value.

Voorlopig testresultaat

Results of the effluents analyses from the SBR (IBA) and the membrane units

Effluent	Phosphorus				Ammonia			Nitrate	
	PO ₄ ³⁻	P	P ₂ O ₅	%	NH ₃ -N	NH ₃	NH ₄ ⁺	NO ₃ -N	NO ₃ ⁻
<div style="display: flex; align-items: center;">  Influent: WWTP Leeuwarden </div>									
SBR (class 3a)	23.9	7.8	17.9		0.61	0.74	0.78	19.9	88.22
<div style="display: flex; align-items: center;">  </div>									
Membrane	0.4	0.1	0.2	98	0.66	0.81	0.85	21.1	93.5

Toegepaste technologie

- Biologische zuivering (SBR principe)
- “Zand”-filtratie met geselecteerd filtermedium
- Nano-membraanfiltratie
- Sensortechnologie

Nazuivering met Nano-filtratie

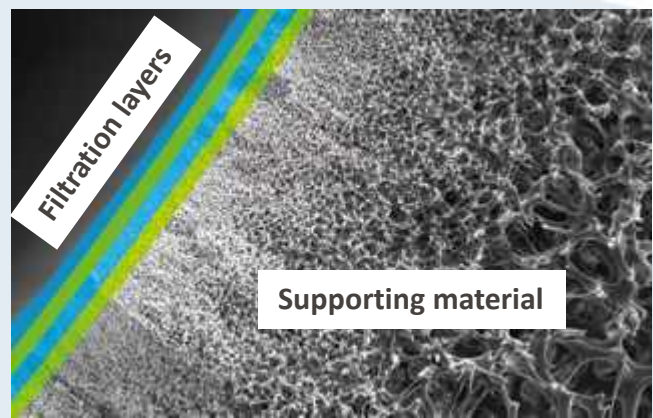
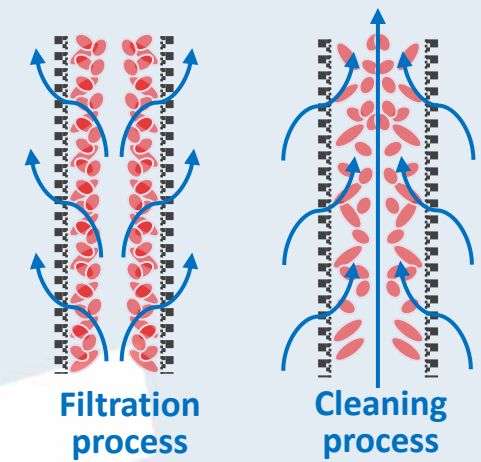
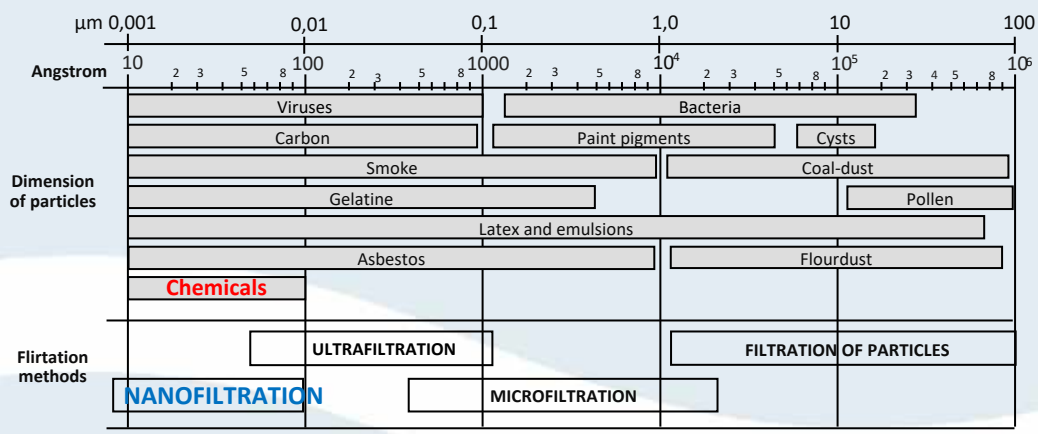

Membrane type : Hollow Fiber
 Material : PES
Removal of:
 - Micro-pollutants
 - Pesticides
 - Medicines
 - Colour
 - Phosphate

Ervaringen tot nu toe

- Streefwaarden zijn haalbaar
- Uitdagingen:
 - Beheer en onderhoud
 - Operationeel houden
 - Onderhoud tegen aanvaardbare kostprijs



Noodzakelijke ontwikkelstappen

- Juiste en betrouwbare technologie vaststellen
- Continue kwaliteitscontrole op effluent
- Robuuste en betrouwbare sensors

En drinkwater dan?

- Het is (nog) niet mogelijk om kwaliteit te garanderen
→ (betaalbare) sensortechniek is nog niet beschikbaar
- Bovendien, slechts 2% van de waterbehoefte is drinkwater

Stelling:

**'Ook al kunnen we drink(baar) water produceren,
het zal in de praktijk worden gebruikt als
huishoudwater'**

Van afvalwater naar drinkwater
Van zwart water tot tafelwater
NEREUS technologie, van grijs
afvalwater tot drinkwater



VAN ZWART WATER TOT TAFELWATER

Pieter Derboven
BOSAQ





PROJECT GUST'EAUX

- Josper Grill; 90 couverts/d
- Collectief te optimaliseren gebied
- Lokale opzuivering afvalwater & hergebruik
- Primeur in Vlaanderen
- Kick-off 10/10/2019; looptijd 3 maanden



TECHNOLOGIE: COMBINATIE BIOLOGISCHE ZUIVERING MET FYSISCHE METHODEN

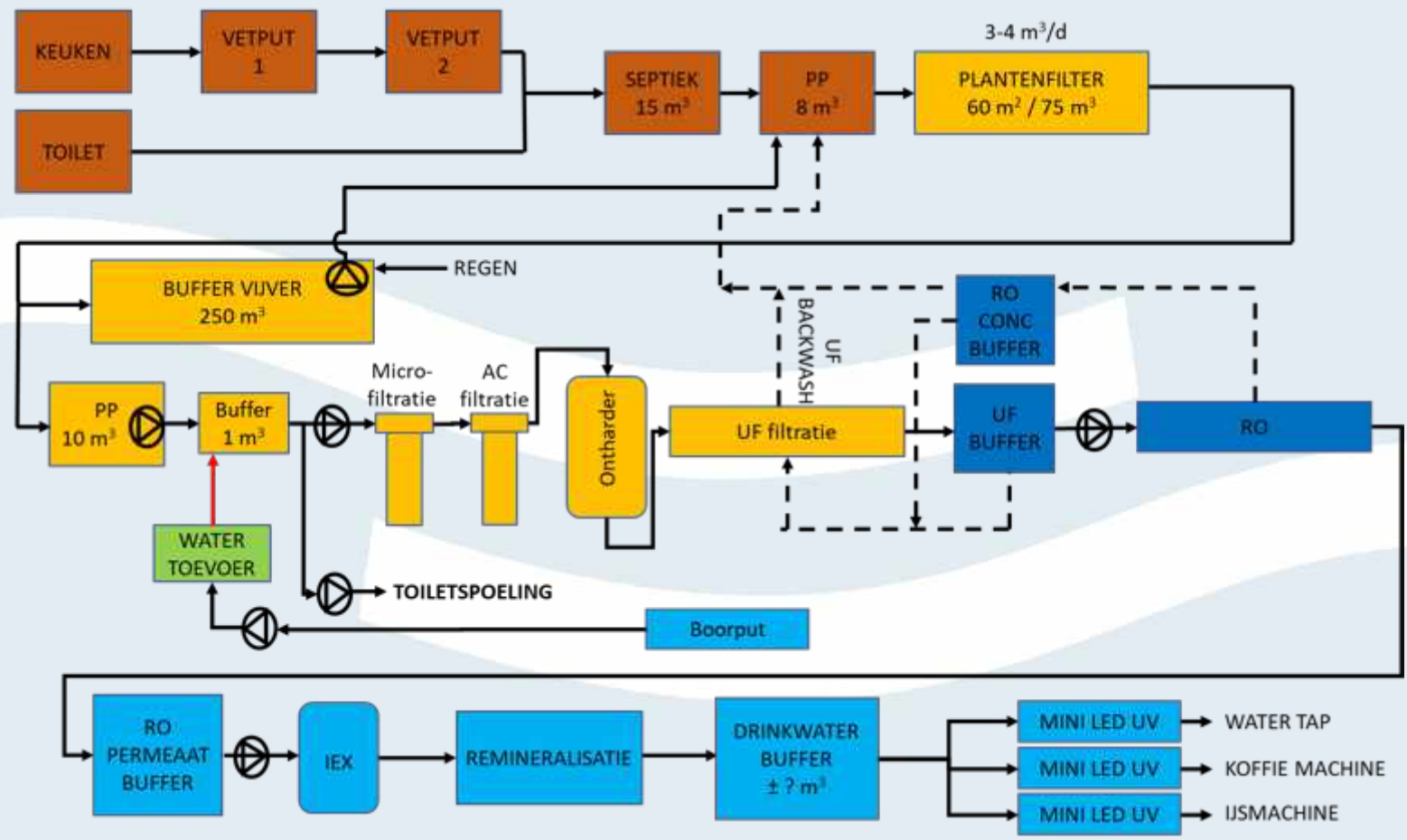

STAP 1: VETVANG – SEPTISCHE PUT – PLANTENFILTER

- Hergebruik voor toiletspoeling
- Verwijdering van:
 - COD
 - Zwevende stof
 - NH_4^+
- Influent kwaliteit:

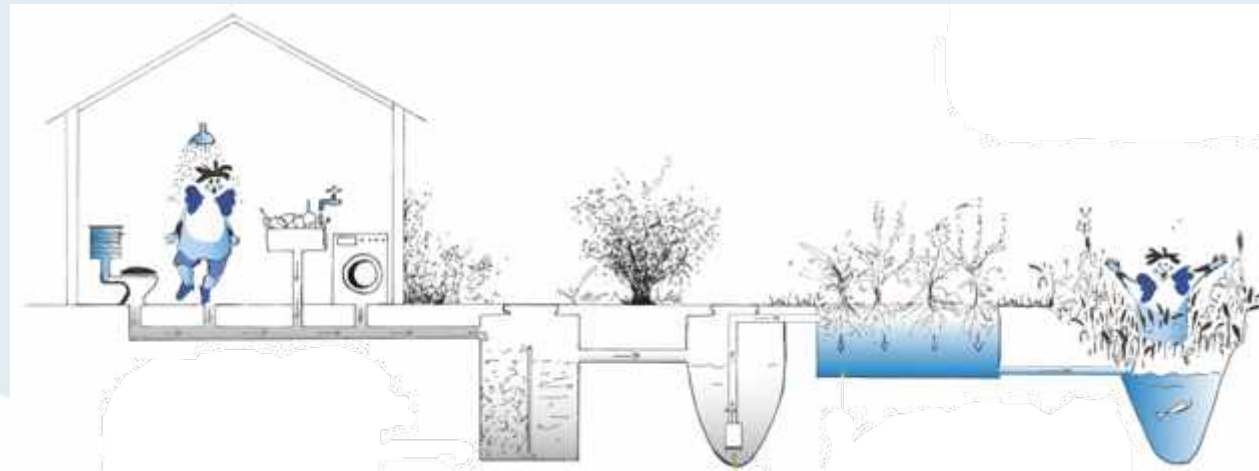

pH	6.8 - 7.7
Temperatuur (°C)	9 - 20
Conductiviteit (µS/cm)	307 - 1577
Zwevende stoffen (mg/L)	18 - 161
COD (mg/L)	36 - 356
P _{totaal} (mg/L)	0.1 - 5.0
SO ₄ (mg/L)	4 - 69
NH ₄ -N (mg/L)	2 - 31
NO ₂ -N (mg/L)	0 - 8
NO ₃ -N (mg/L)	0 - 12

STAP 2: OPWAARDERING TOT DRINKWATER

- Inkomende kwaliteit:

pH	6.7 - 7.3
Temperatuur (°C)	9 - 20
Conductiviteit (µS/cm)	795 - 2035
Zwevende stoffen (mg/L)	0.2 - 17.1
COD (mg/L)	9 - 31
P _{totaal} (mg/L)	1.9 - 4.1
SO ₄ (mg/L)	16 - 74
NH ₄ -N (mg/L)	0.01 - 3.3
NO ₂ -N (mg/L)	0 - 4
NO ₃ -N (mg/L)	0.2 - 9



RESULTATEN: ONLINE OPVOLGING VIA IoT

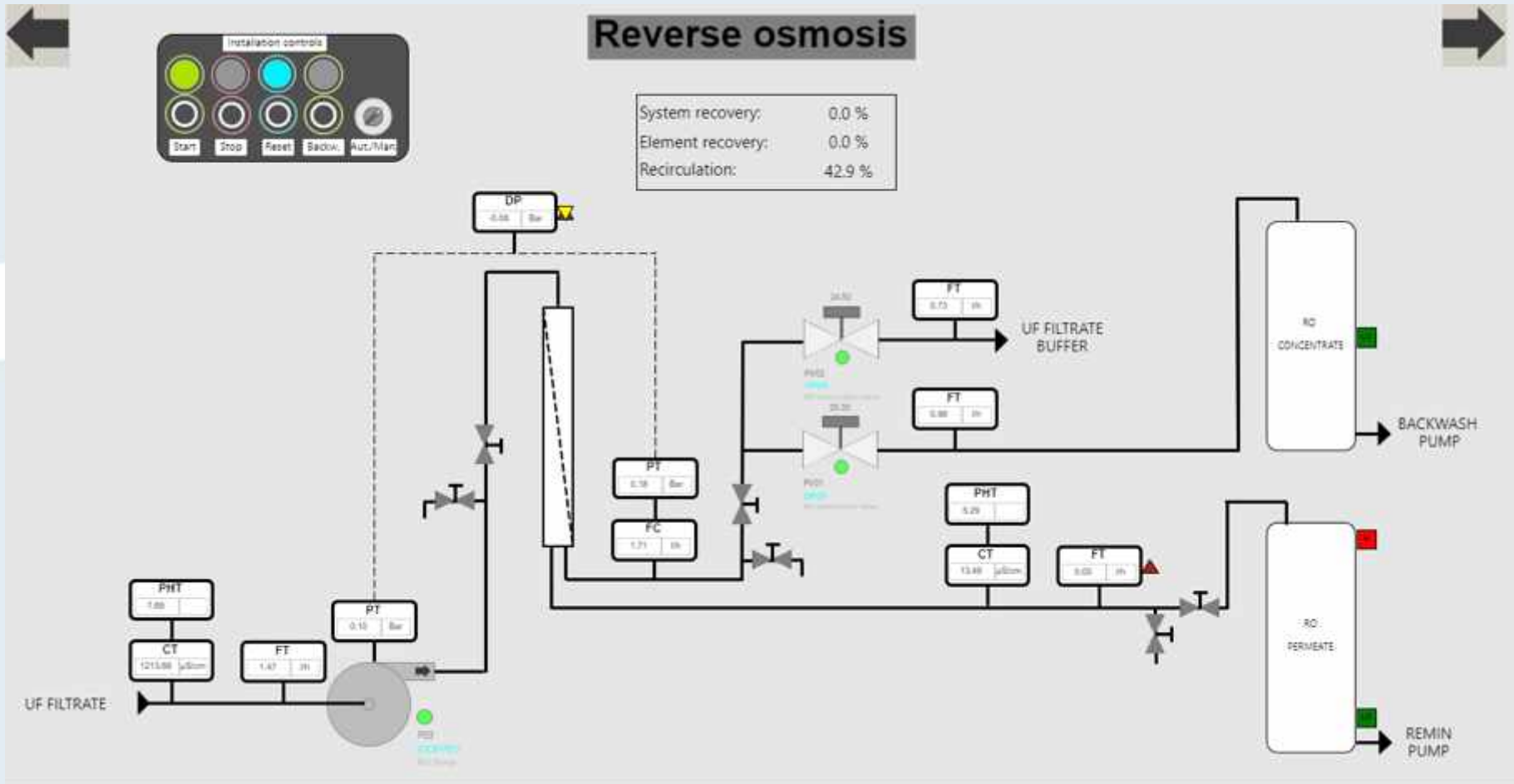

RESULTATEN: ONLINE OPVOLGING VIA IoT

- Bij stilstand elke 12 u flush UF en RO membraan
- Zoveel mogelijk continue operatie RO
- Vermijden stilstand drinkwatertank → recirculatie over LED-UV

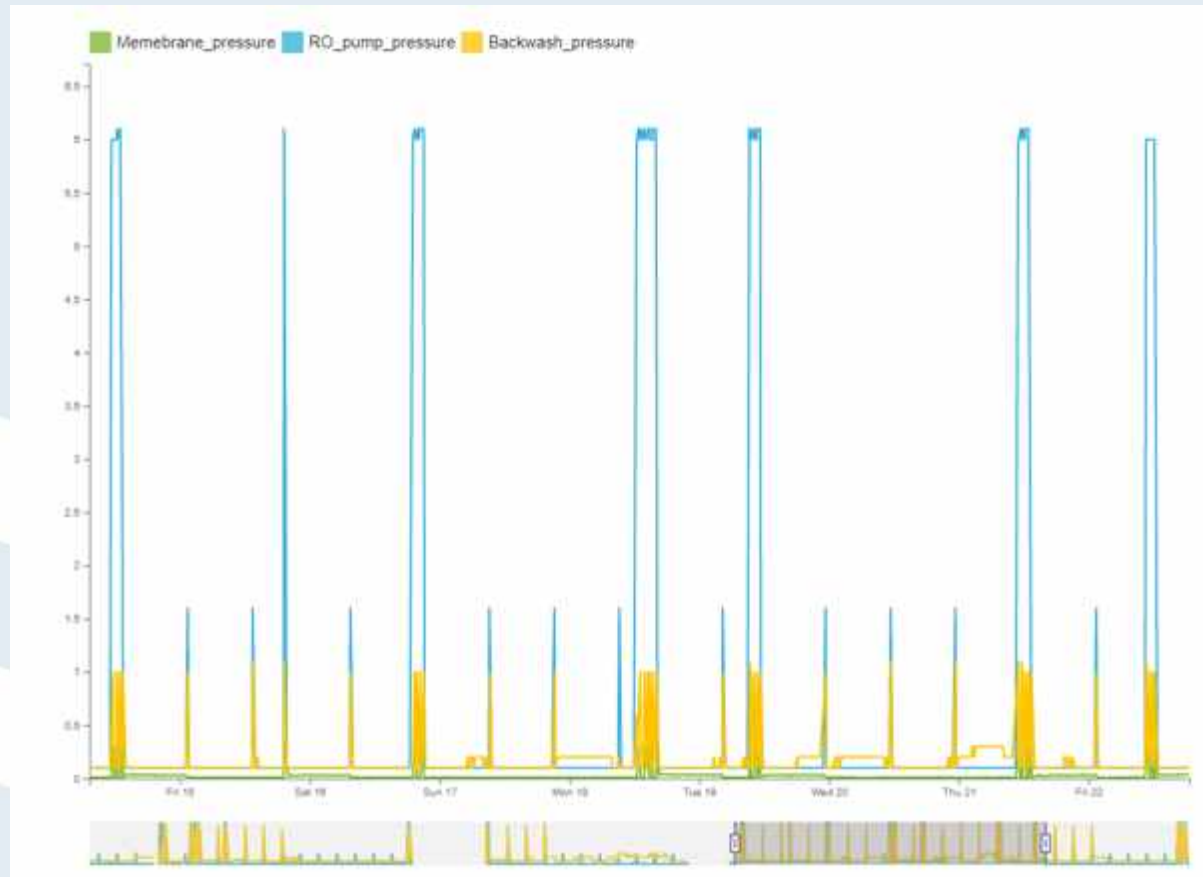

RESULTATEN: DRINKWATERKWALITEIT

- Stabiele uitgaande drinkwaterkwaliteit @ 100 L/u:
 - $\text{NH}_4^+ < 0.02 \text{ mg/L}$
 - $\text{NO}_2^- < 0.03 \text{ mg/L}$
 - $\text{NO}_3^- < 4 \text{ mg/L}$
 - pH: 7.5 – 8.0
 - Hardheid: 50 – 55 mg CaCO_3/L
 - Conductiviteit: $\sim 100 \mu\text{S/cm}$



DOEL PROJECT

- Informeren belang **lokaal water(her)gebruik**, i.h.b bij afwezigheid connectie riool/drinkwater net
- Initiëren van **nieuwe engagementen/wetten voor circulaire** toepassingen
- Demonstratie van **technologische haalbaarheid**
- Voorlopig **niet de bedoeling economische case** aan te tonen

TOEKOMSTIGE ONTWIKKELINGEN

- Gedetailleerde **microbiële studie** → flow cytometrie
- Laboratoriumonderzoek **medicijnresten**
- Verwijderingsefficiëntie **microplastics** in deelstappen

Van afvalwater naar drinkwater
Van zwartwater tot tafelwater
**NEREUS technologie, van grijs
afvalwater tot drinkwater**



water-link

Decentrale drinkwater productie

Facts & figures

CUSTOMERS

652.604



PRODUCTION VOLUME

139.778.974 m³



EMPLOYEES

464





TURNOVER

€ 162.188.847

Water-link: Verzorgingsgebied

Drinking water & Sewage

MAP LEGEND

-  Drinkwater distributie & riolering
-  Enkel riolering
-  Enkel drinkwater distributie

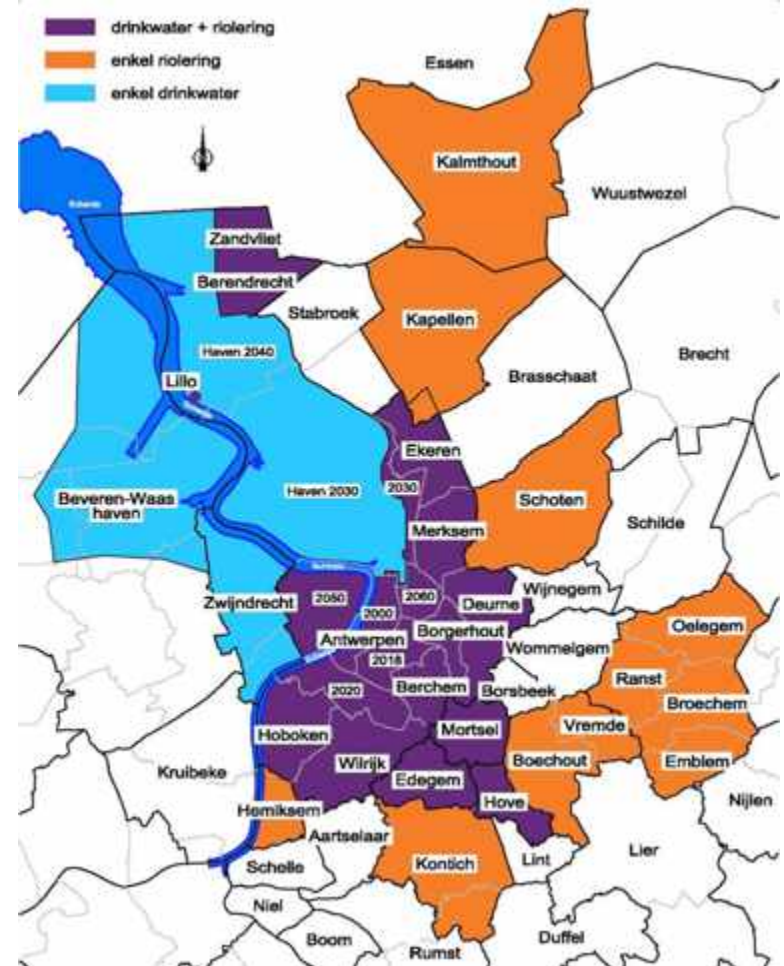

Water-link: towards a circular footprint

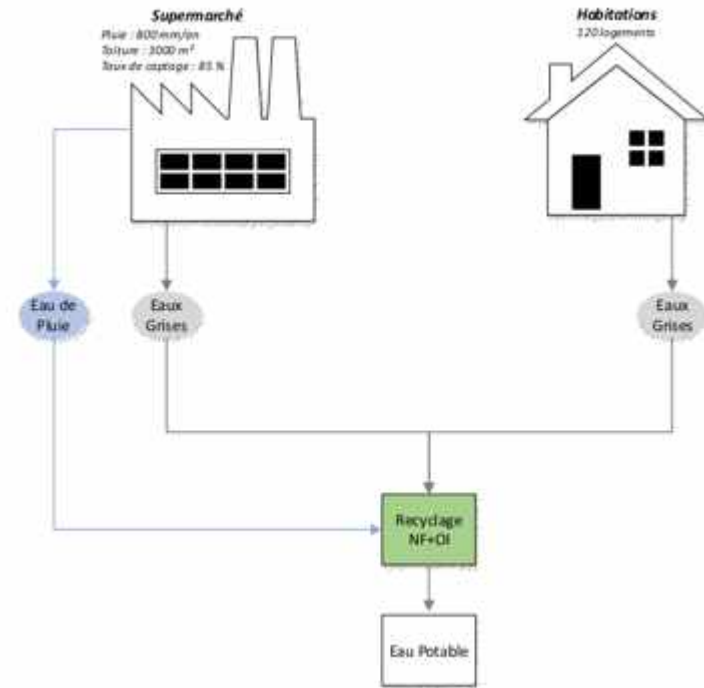
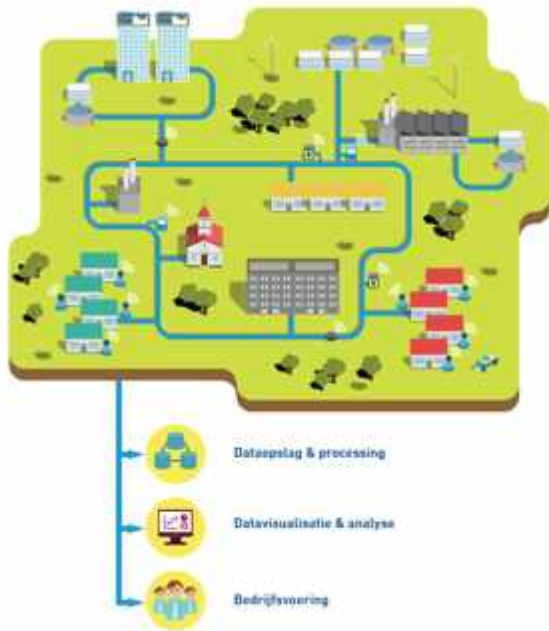

Water-link: towards a circular footprint

Interreg 
EUROPESE UNIE
2 Seas Mers Zeeën
Europees Fonds voor Regionale Ontwikkeling

 **water-link**

Projecten

1. Operationele projecten

- I. (Piloot Walem)
- II. Plein Public Antwerpen
- III. Residentieel project Edegem
- IV. Gedempte zuiderdokken Antwerpen



2. Projecten in onderzoek

- I. Groenplaats-eiermarkt Antwerp
- II. Revive Edegem

I. Pilot Walem

- 2016-2019
- Hergebruik van regen, grijs en zwart water
- Zonder remineralisatie unit
- doelstelling: drinkwaterkwaliteit



I. Pilot Walem PFD

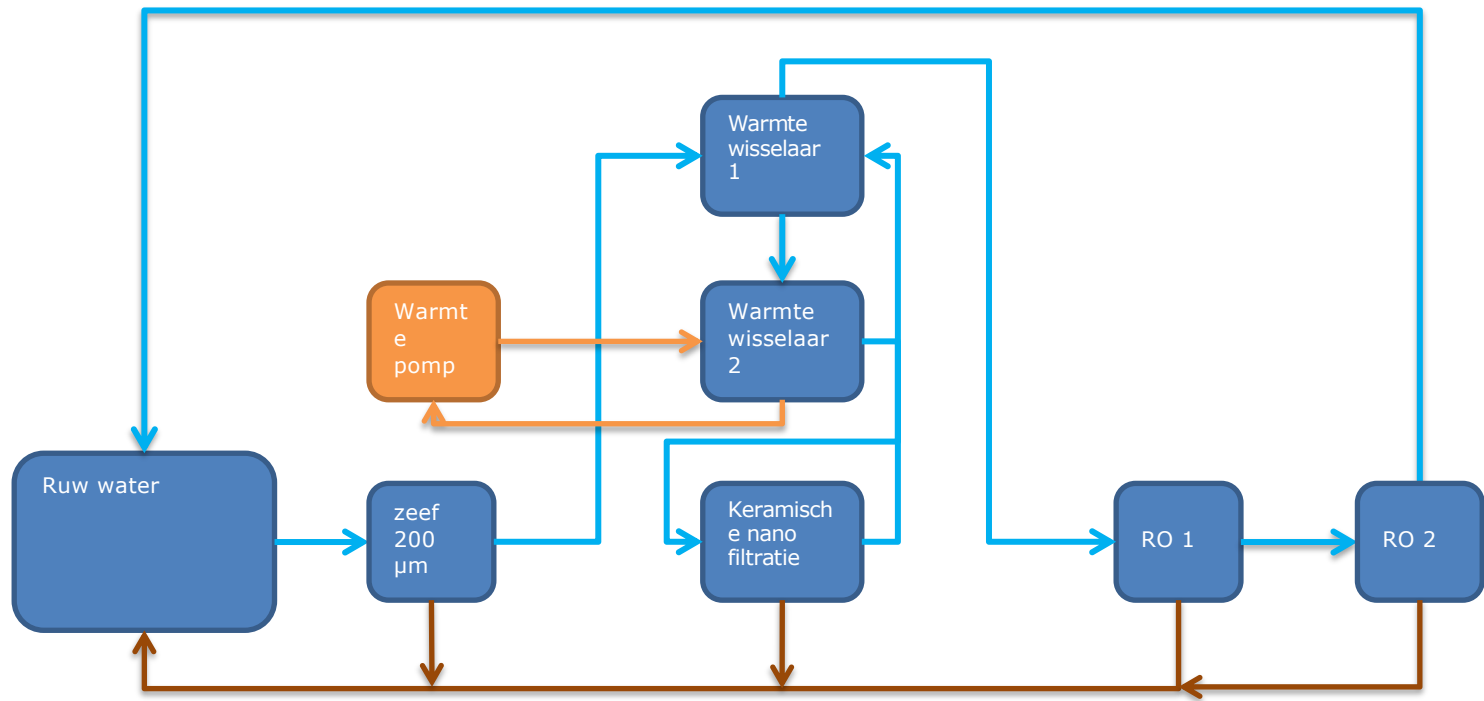

I. Piloot Walem



Goede resultaten



Goede resultaten met aandacht
voor

Ammonium
THM's (desinfectie producten)



Middelmatige
resultaten

kleur
Ammonium
TOC
bacto

II. Interreg project Plein Public

Ruw water bron: mengeling van grijs & regen water(restaurant)

Doelstellingen

- 1st live test in direct potable re-use vanuit grijs water
- Validatie resultaten door regulerende overheid
- Testlocatie voor acceptatie metingen
- Quality control & event detection



II. Interreg project Plein Public

Initial set up

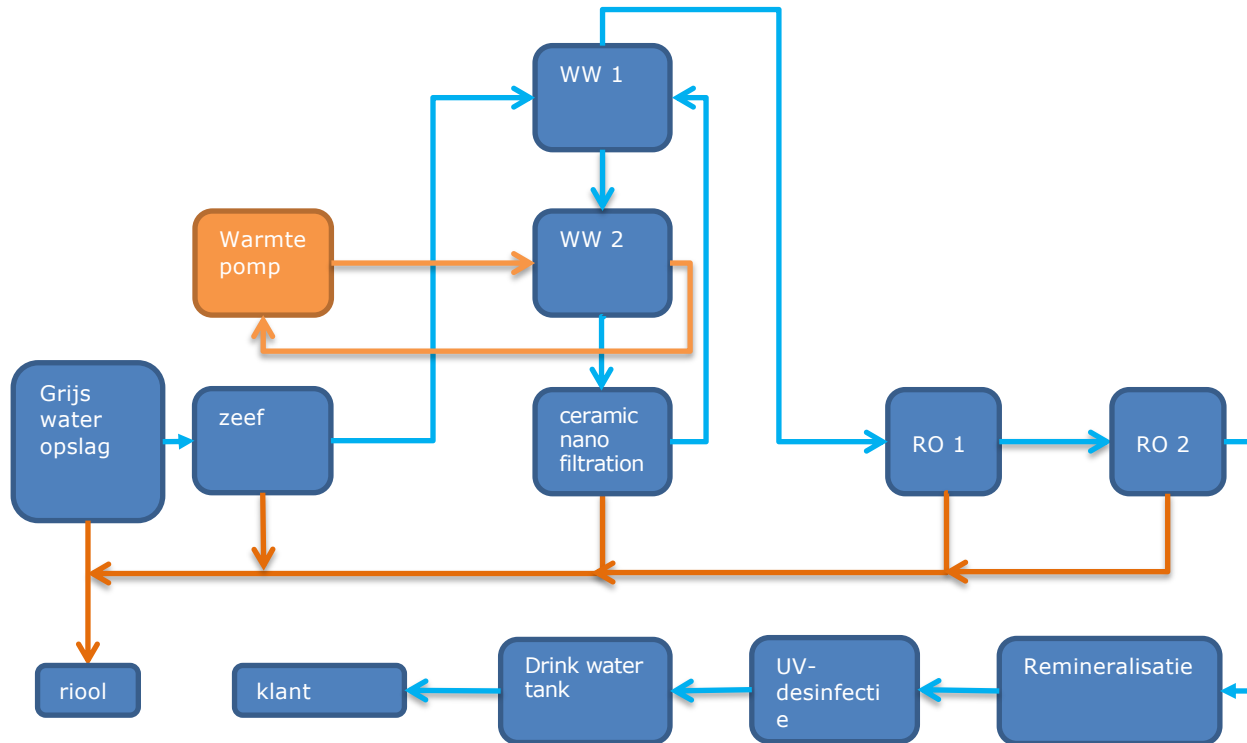

II. Interreg project Plein Public

- hoge TOC waarden in permeaat
 - Low molecular organic's (<300 da)
- Geur!



- Selectie RO2 membraan
- Oxidatie + adsorptie organic's
- Optimalisatie remineralisatie
- Oxidatie (sulfide)

- Hoge vet waarden in ruw water

- Installatie van vetvang in keuken
- Opleiding van de afwasser

II. Interreg project Plein Public

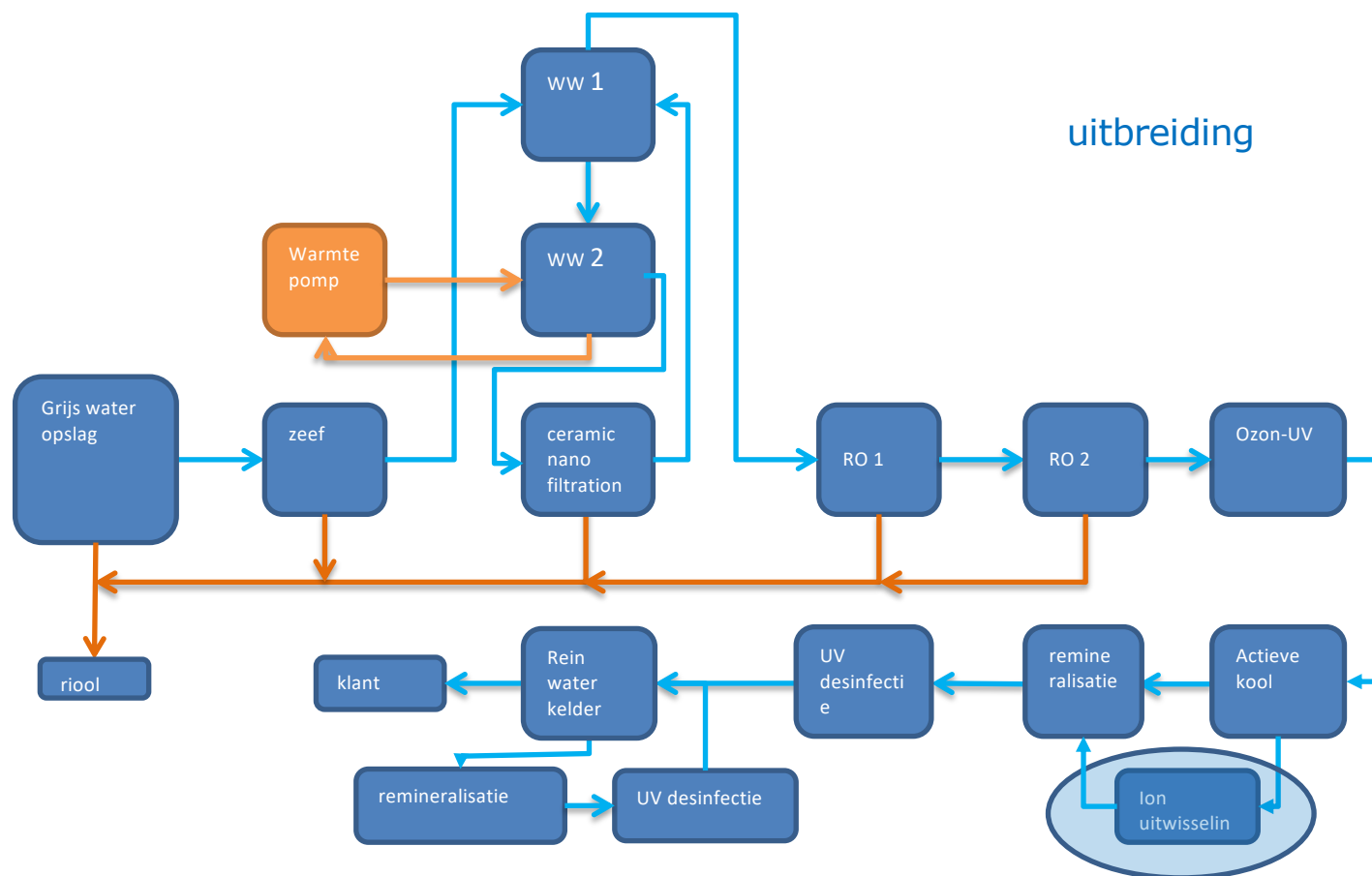

III. Residentieel project

Doelstelling

Live test grijs water + regen water
=> drink water kwaliteit
Demo project
Test op acceptatie => circulariteit
binnen een gezin
Quality control & event detection

Timing

Installatie & opstart
24/9 tot 5/10/2018
Expansie installatie: Q3 2019



IV. Gedempte zuiderdokken

Samenwerking tussen stad Antwerpen, AG Vespa, water-link & Aquafin

Opstart project: Q3 2019

Verschillende verbruikers regenwater

Eerste levering voorzien voor: 2021-2022



IV. Gedempte zuiderdokken

Fact & Figures	
Regenwater buffer	1.500 m ³
Verwacht regenwater volume	17.400 m ³ /j
Water re-used	15.400 m ³ /j
Water re-used voor drinkwater	11.900 m ³ /j
Overloop volume	2.000 m ³ /j
Buffer leegstand	10%
Gemiddeld verbruik klant	1,5 m ³ /h

2. Projecten in onderzoek

I. Groenplaats - eiermarkt

regenwater project

timing start project 2023

Samenwerking met stad Antwerpen,
water-link & aquafin

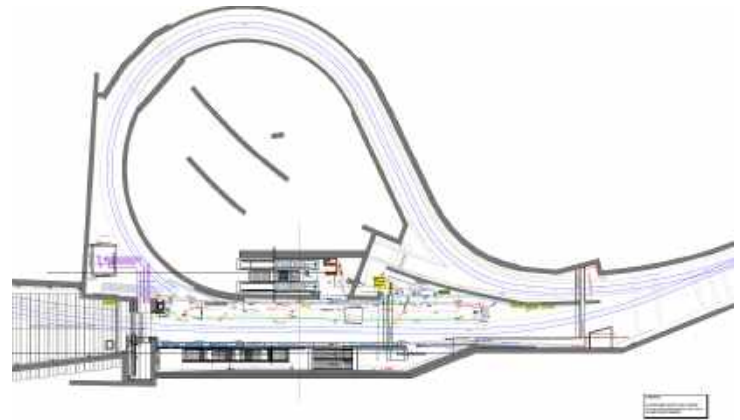

II. Revive Edegem

- Coöperatie tussen Revive, water-link & omliggende bedrijven
- Installatie in kelder appartementsblok
- 350 gezinnen & 3 bedrijven
- Exploitatie door water-link
- Afhankelijk van toekennen subsidie



II. Revive Edegem

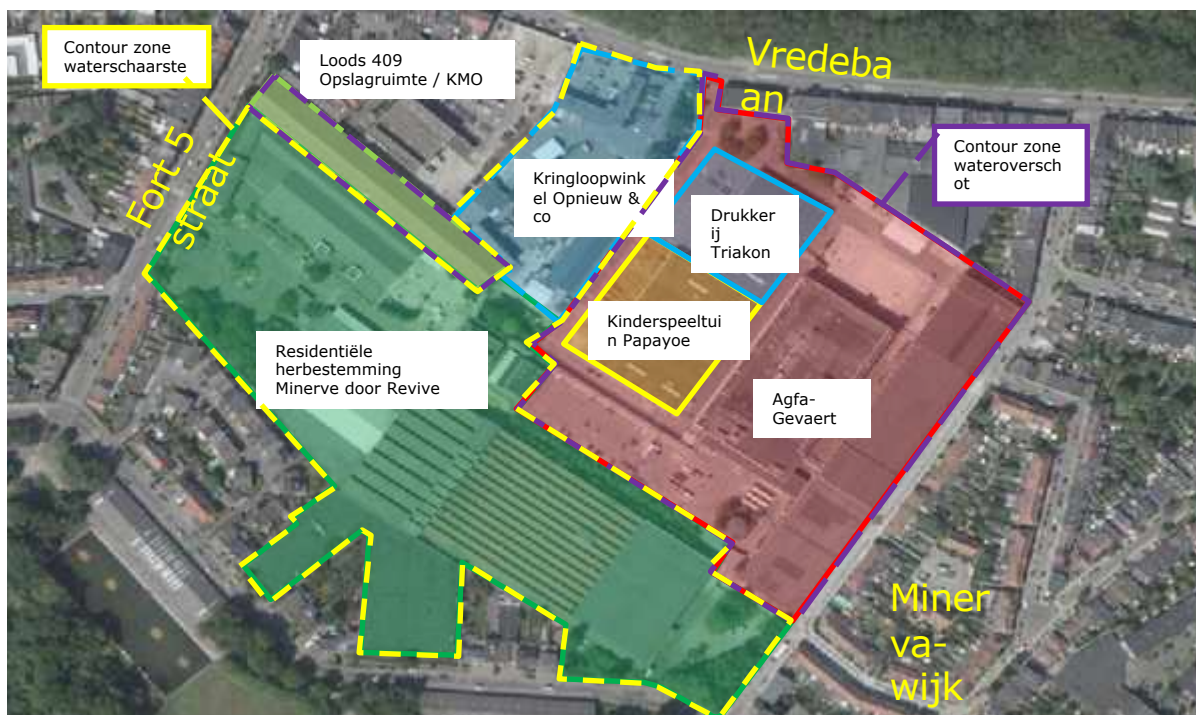

Water-link: contact



Wim Bossaerts

Project lead

Tel 0032 15 307 860

Mechelsesteenweg 66

2018 Antwerpen

www.water-link.be

Q&A

stowa

ATLANTIS
**RIO
NED**
STAD - WATER - HUIS

Vlakwa
VLAAMSE KENNISCENTRUM WATER
FLANDERS KNOWLEDGE CENTER WATER

 **vito**

KENNISEVENT NIEUWE SANITATIE

Een samenwerking over de grenzen heen...

28 November 2019 – Bovendonk, Hoeven (NL)

TERUGWINNING GRONDSTOFFEN



WOWproject, winning grondstoffen uit afvalwater
Waterhergebruik in recreatiepark en woonwijk
Enzymatische omzetting cellulose

PROJECT WOW! Winning grondstoffen uit rioolwater

28 November 2019

Rinus van Praag - Pulsed Heat



*Waarom wordt op dit moment
minder dan 1% grondstoffen
hergebruikt?!*

- A. Het kan technisch gezien niet
- B. Er is geen markt voor
- C. Het mag juridisch gezien niet
- D. Geen van de antwoorden is waar
- E. Alle antwoorden zijn waar



Met het WOW! project willen wij:

- Laten zien dat terugwinnen van grondstoffen uit rioolwater mogelijk is
- Marktpartijen kennis laten maken met de potentie van grondstoffen uit rioolwater
- Een Europees kader creëren voor te doorlopen stappen van afvalstof naar grondstof

Deelnemers WOW!



WOW Algemeen

- **WOW!** - **W**ider business **O**pportunities for raw materials from **W**astewater
- Subsidieproject Interreg NWE: → 6 Miljoen budget
- Zeer international: → 6 landen
- **SAMENWERKEN!!!**

Elementen: 3 technische pilots marketing producten wettelijk kader

Nederlands deel: Cellulose Pilot → RWZI EDE

WOW! Cellulose Pilot → ontleden met vuur !



Partners in cellulose pilot:



- Hardware leverancier
 - Fijnzeven
- Trekker juridische en wettelijke werkgroep



- Hardware leverancier
 - Ontwatering
 - Droger
 - Pyrolyse
 - Kool activatie



- Hardware leverancier
 - Locatie inrichting en aansluitingen
- Locatie: RWZI Ede
- Overall projectmanagement

Koolstof waardering in cellulose plant

CONCEPT:

Koolstofbron

(=cellulose) uit influent RWZI, nu met “negatieve waarde”, transformeren naar positief gewaardeerde producten.



Afvangen grondstof

-> Zeefgoed met 70% cellulose



Vorbewerken half fabrikaat

-> gedroogde pellets

Opwerken tot product

-> pyrolyse tot 4 producten
-> pyrolyse gas
-> azijnzuur
-> pyrolyse olie
-> kool/as fractie
-> na activatie: actief kool



Existing Fast Pyrolysis process

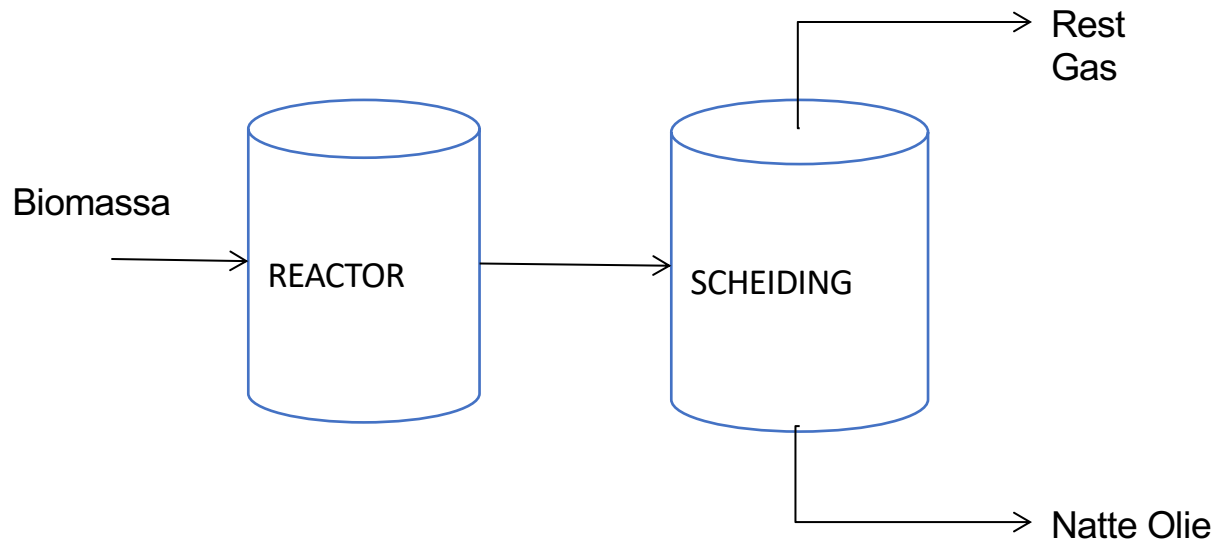

PyroFlash Fast Pyrolysis process

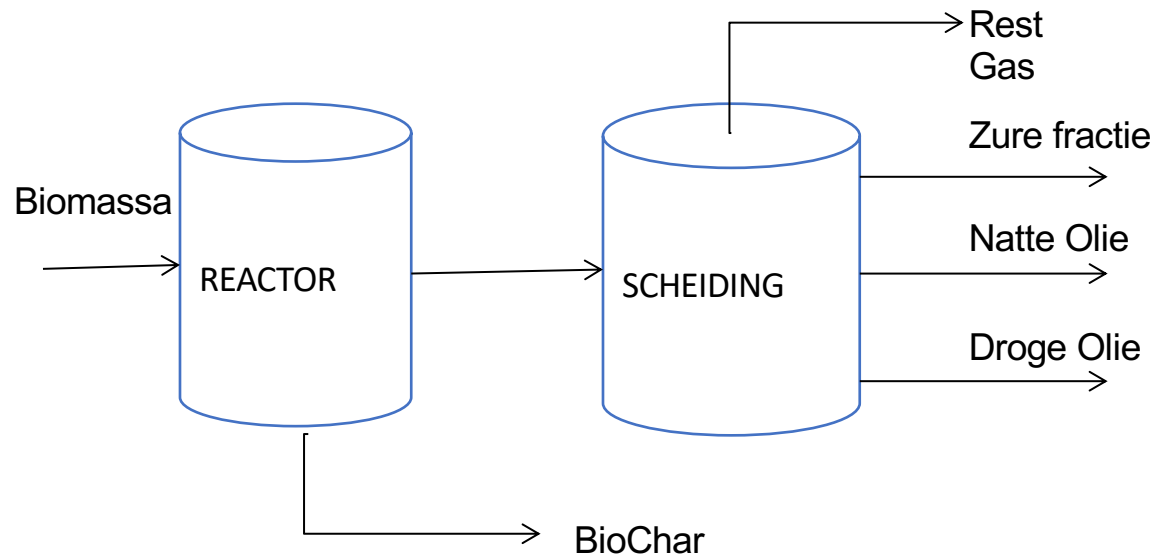

PyroFlash Pyrolyse

Fast Pyrolyse:



Cellulose Pilot

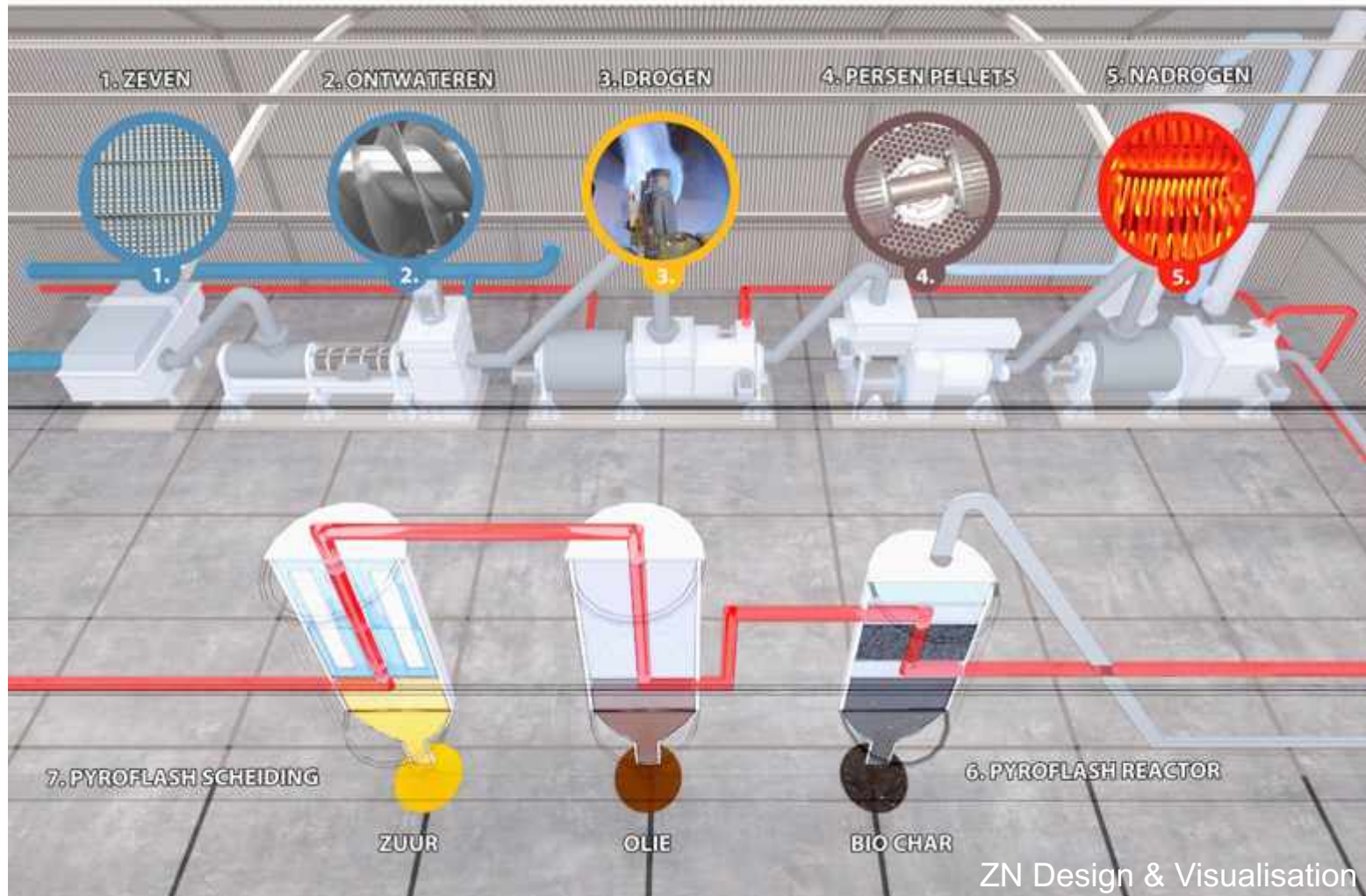

DOELSTELLING CELLULOSE PILOT RWZI EDE

- Pyrolyse gas 800 kg/dag
- Zure fractie 180 kg/dag
- Pyrolyse olie 300 kg/dag
- As-/ koolfractie 180 kg/dag



SUBDOELSTELLING: ACTIVEREN

- Toepassen actief gemaakt kool geen onderwerp uit WOW!
- Geactiveerde kool wel onderzocht en adsorptieve eigenschappen bepaald.

	begin		adsorptie		eind		adsorptie	
	concentr.	concentr.	actieve kool	P'brecht	concentr.	act. kool	zeefgoed	concentr.
gids parameters	concentr. (ug/l)	concentr. (ug/l)			concentr. (ug/l)			concentr. (ug/l)
amidobenzozijnzuur	0.290	0.29	0%		0.290	0%		0.290
benzotriazolone	4.210	0.55	87%		0.696	83%		3.831
diclofenac	0.840	0.10	88%		0.661	21%		0.840
gabapentine	4.900	4.90	0%		4.900	0%		4.900
jomeprol	50.600	50.60	0%		50.600	0%		50.600
lopamidol	4.900	3.14	36%		4.696	4%		4.900
irbesartan	1.890	0.42	78%		0.953	50%		1.890
lidocaine	0.380	0.08	79%		0.291	24%		0.380
metformine	3.260	3.26	0%		3.260	0%		3.260
naproxen	1.490	0.15	90%		1.164	22%		1.490
oxazepam	1.180	0.09	92%		0.874	26%		1.180
sotalol	1.330	0.17	87%		0.716	46%		1.330
deet	0.170	0.03	84%		0.122	28%		0.167

Onderzoek naar het potentieel van biochar als adsorbens voor de verwijdering van organische pollutanten bij end-of-pipe waterzuivering



universiteit
hasselt

al process technology

Rick Segers
Promotor : Dr. ir. Kristel Sniegowski
Begeleider : Ina Jansen Straten

Apparatuur cellulose Pilot

Cellulose screens (Cirtec)



Dewatering unit



Falling curtain
dryer



Pellet press

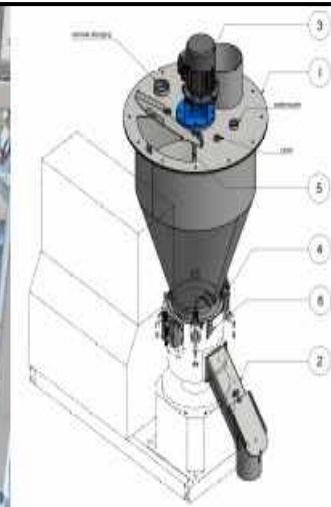

Apparatuur cellulose Pilot

Deep Dryer

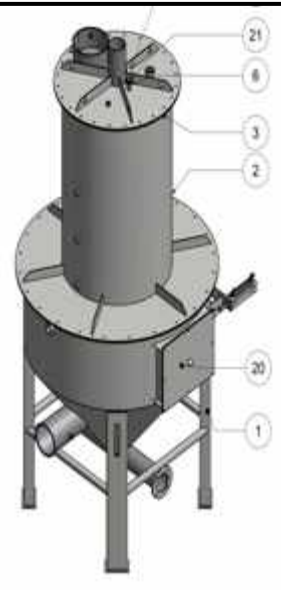

Pyrolysis burner



**Pyrolysis
installation**

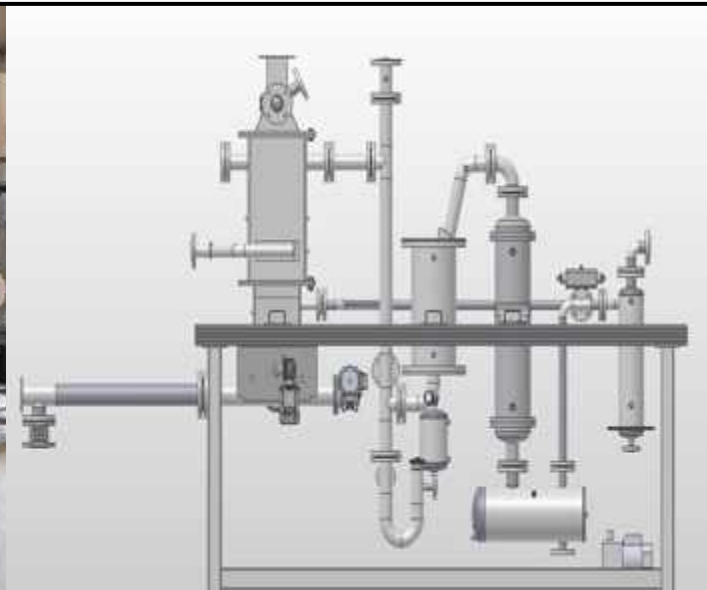

Pyrogas co-combustor



Stand van zaken Bouw Cellulose Pilot

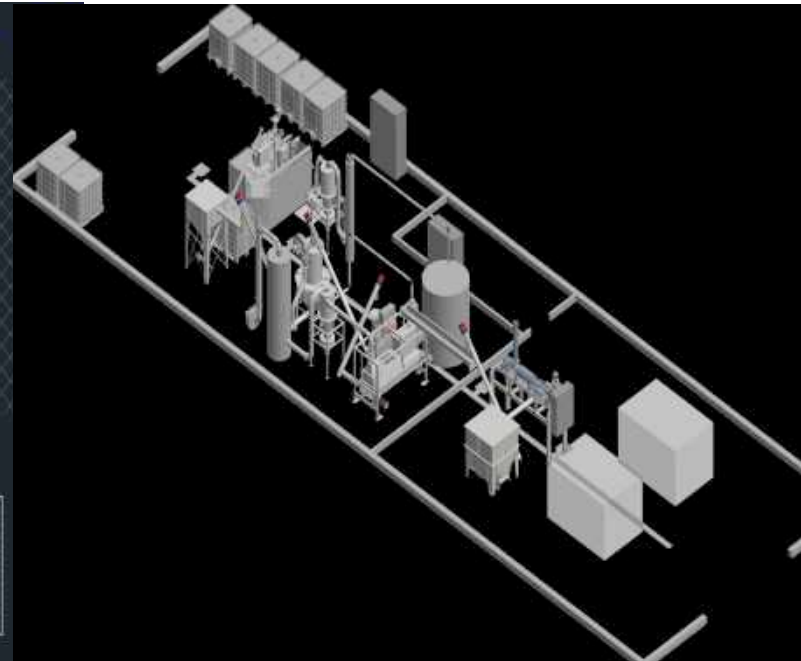
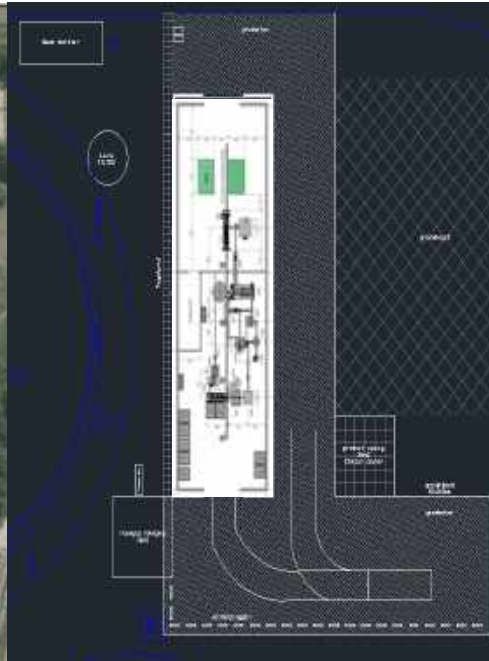

Stand van zaken Afzet Producten

- 1) Pyrolyse gas Eigen gebruik, brandstof voor droger
- 2) Zure fractie Nu als C-bron in Actief Slib reactor. Onderzoek naar mogelijkheden bij andere WOW! Pilots.
- 3) Pyrolyse olie Stookolie, samen met gebruiker wordt onderzocht of olie inzetbaar is voor toepassing in stoomketel, serieuze interesse!
- 4) As/koolfractie Vooralsnog voornemen zelf toe te passen op RWZI, wordt onderzocht



Vragen?

WOWproject, winning grondstoffen uit afvalwater
Waterhergebruik in recreatiepark en woonwijk
Enzymatische omzetting cellulose

Water reuse : Theme and leisure park

Michel Danau
Veolia Water



Outline



- ❖ *Why water reuse*
- ❖ *Water reuse – market perspectives*
- ❖ *Barriers and opportunities*
- ❖ *Veolia key technologies*
- ❖ *Case studies*



Why are we talking about water reuse?

Freshwater is a finite resource

- *Balancing supply and demand:*
 - Complicated and sensitive urban water cycle.
 - Climate change, shortages.
 - Water needs overlap and conflict.
- *Quality & quantity: regulations are changing:*
 - Past issues: quality and wastewater treatment.
 - Today issues: water scarcity.
 - Practical, social and economic implications.
- *Environmentally sound water management:*
 - Complexity of man's influence on the water cycle.
 - Deterioration of the local ecology.



What water?

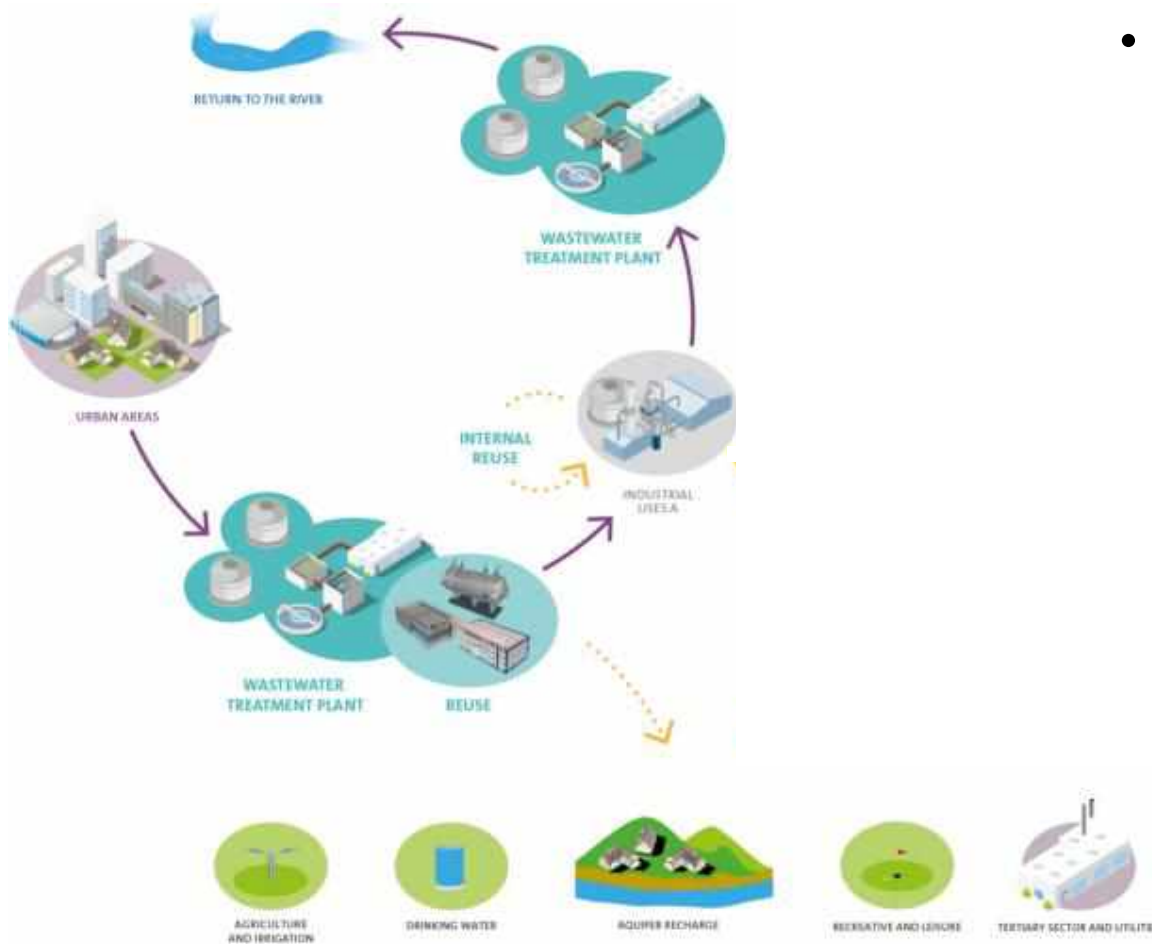

- 2 types of water sources may be used for water reuse:

- *Municipal reclaimed water*
- *Industrial reclaimed water*

Growing needs worldwide

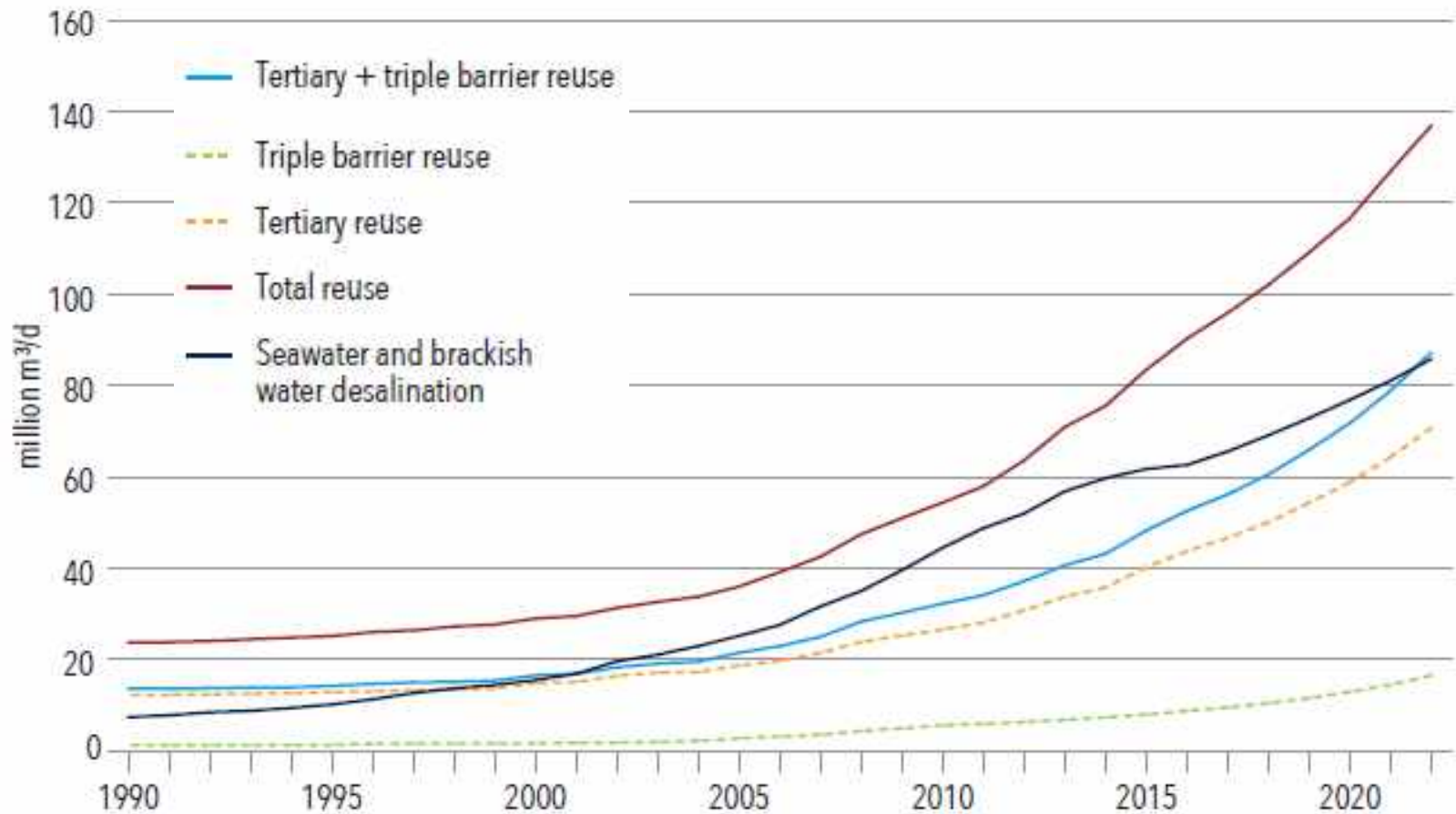

Source: GWI

Reuse ~X 2 every 7 years

Water reuse for what application?

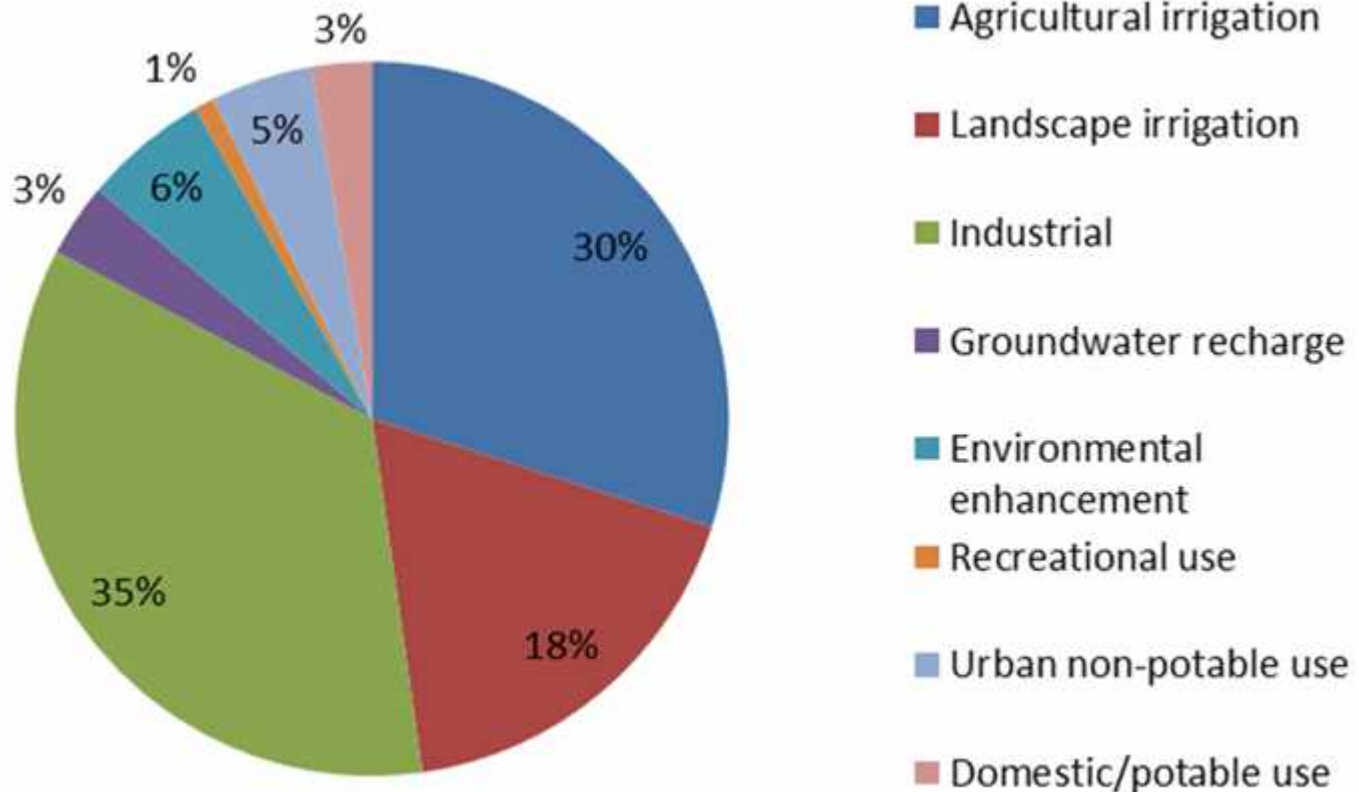

2018 data

~50 % for irrigation
35% for industrial users (from 28% in 2010)

Geographical overview

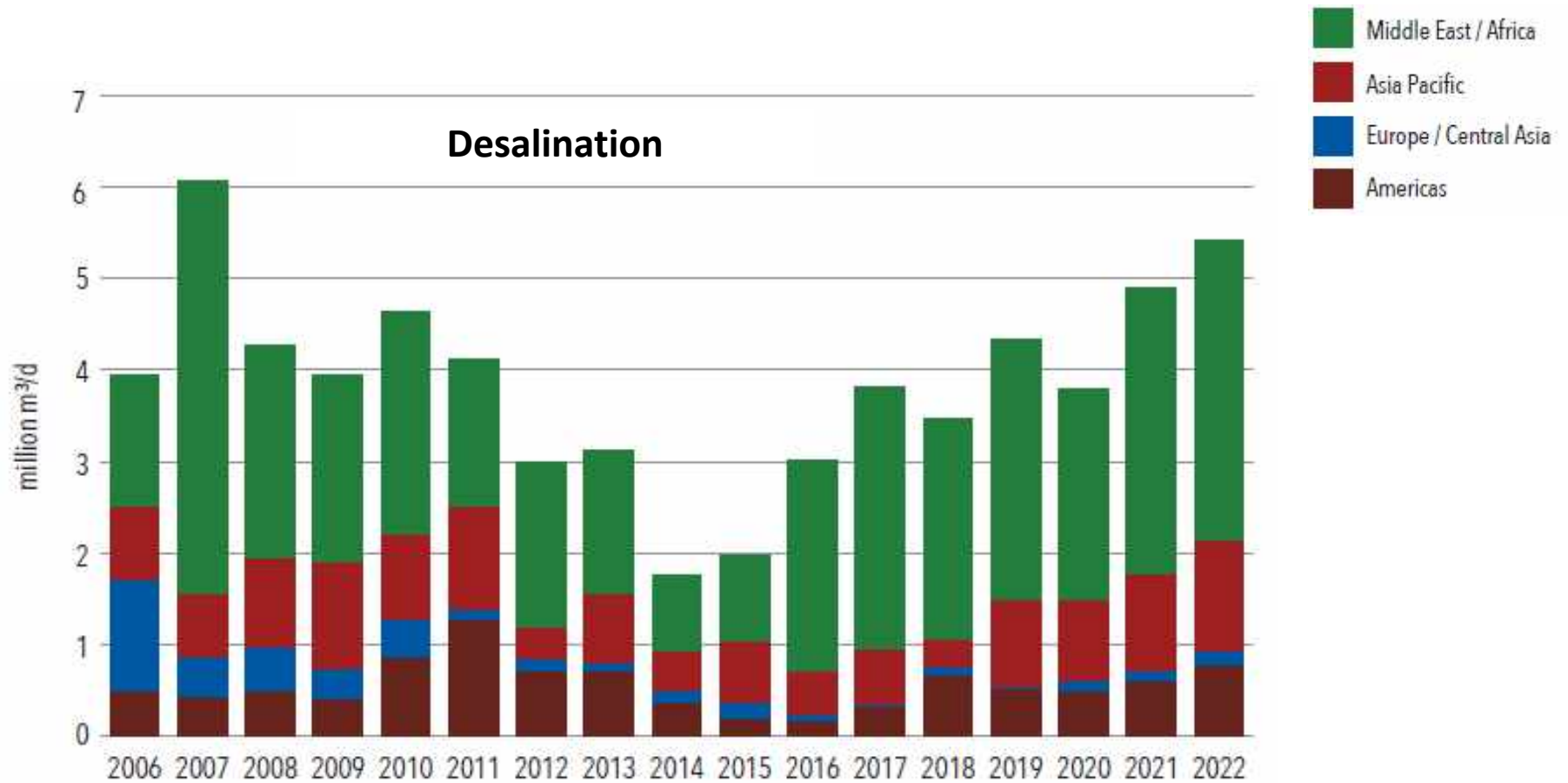

Geographical overview

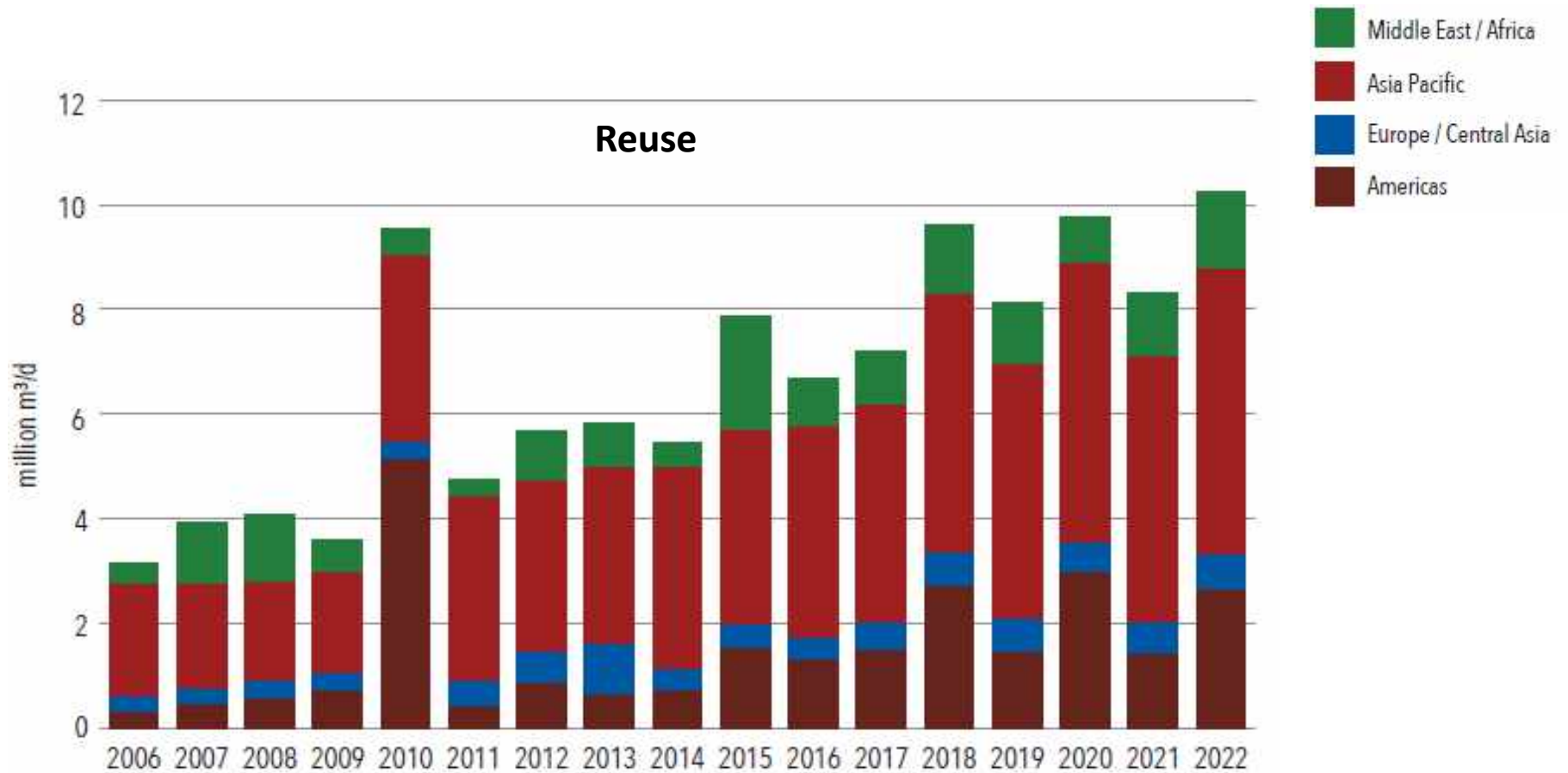

Veolia key technologies



What process line?

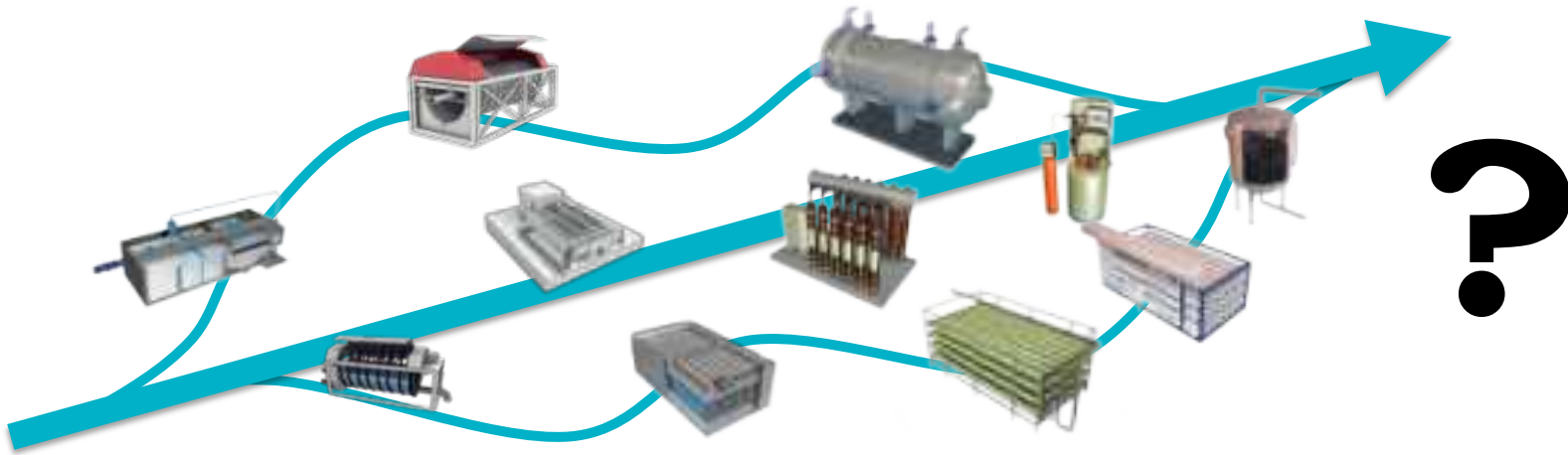

Always a case by case story according to:

INCOMING WATER QUALITY

REUSE PURPOSES

SITE CONFIGURATION

LOCAL REGULATION

Municipal case studies



Municipal water reuse:

- *For recreation purpose : Theme park, France*
- *For urban purpose : Darling Quarter, Australia*

Theme park Paris (France)

Context & needs

Reduce park's drinking water consumption
in a department where several droughts occur.

Treat wastewater from

- 2 theme parks
- Hotel park

Water 'Reuse' needs

- Irrigation green parks
- Technical installations (cooling, heating,...)
- Maintening lake water level & quality



- ❑ Biosep *MBR*
- ❑ Hydrotech for tertiary P polishing
- ❑ UV
- ❑ Chlorination

commissioning
2014

WWTP capacity
3 600 m³/day

reuse capacity: **25%**

904 m³/day

Description WWTP & reuse

- Start-up : April 2013
- 1 buffer bassin
- 1 coarse sieve (6 mm)
- 2 fine sieves (1 mm)
- 1 Aerobic bassin « Azenit » for biological N & P removal
- 3 mambrane trains (Biosep)
 - ZeeWeed 500
 - 2 cassettes/ train
- 2 centrifuges (1+1)
- 1 UV disinfection + chlorination
- 1 storage & distrubution system

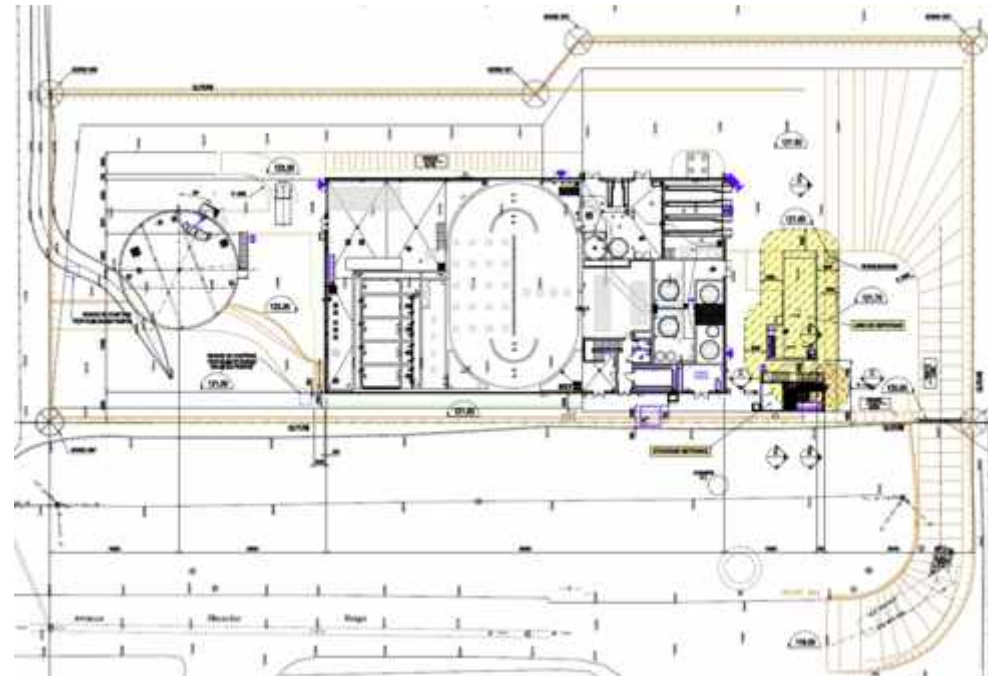

Hydraulic & organic loads

	DRY WETHER
Equivalent habitants (base 150 L/EH)	17 500 Eh
Flow/day	3 500 m ³ /j
Average flow/h	150 m ³ /h
Max flow/h	315 m ³ /h

	Influent		Effluent	
	Contract (kg/d)	Reality (kg/d)	Contract (mg/l)	Reality (mg/l)
BOD5	1050	431	6	2
COD	2625	1050	30	14
SS	1525	543	5	2
NTK	330	166	2	1,1
NH4	-		0,5	0,3
Pt	65	18	0,5	0,3

Reuse parameters

Parameter	Niveau de qualité	
	Garantee	Reality
Total coliforms / 100 ml	10	<1
Fecal coliforms/ 100 ml	10	<1
Escherichia Coli / 100 ml	10	<1
Intestinal enterococci/ 100 ml	30	0
Salmonella / 100 ml	0	<6,7*
Legionella Pneumophila/ 100 ml	10	<5
Helminth eggs/ 10L	1	0

Objectif : 100 % recycling treated water for irrigation, power station, park basins and roads

* : the method does not allow to give 0

Darling Quarter - Sydney (Australia)

Context & needs

Follow the **development of a new urban area** consists of shops, offices and leisure areas.

Expand the supply of important initiatives for **sustainable development**, including a **reduction in potable water use by 90%** by the **treatment of rainwater and recycling of treated water** on site.

- Recreational field Irrigation
- Landscape Irrigation
- Toilet flushing
- Cooling Tower Make-Up Tower Facilities



- ❑ AnoxKaldnes MBBR
- ❑ Biosep - MBR
- ❑ RO
- ❑ UV
- ❑ Chlorination

commissioning
2011

WWTP capacity
245 m³/day

reuse capacity: **68%**

166 m³/day

Darling Quarter Development – A success story

- WICA Regulation (NSW) promotes and encourages privately operated reuse schemes
- Forward thinking developers – see the real benefits of Eco Design for commercial buildings and urban developments
- Utilities – driving reuse targets and reduce costs
- Private industry providing innovative technologies and service offerings to the market



Darling Quarter Recycled Water Plant (245 m³/d)

- The process treats 245 m³/day of sewage through sewer mining to produce 166 m³/day of high quality recycled water for reuse for:
 - Toilet flushing and irrigation (50m³/day)
 - Cooling tower make up water (116m³/day)
- 60 000 m³ (60 million litres) of water saved per year
- The recycled water plant combines innovative technologies:
 - Moving Bed Biofilm Reactor (MBBR™)
 - Biosep® Membrane Bioreactor
 - Reverse Osmosis
 - UV + Chlorination



WWTP view

Darling Quarter Recycled Water Plant

- It needs to fit in an area of 150m²
- It's two floors below ground

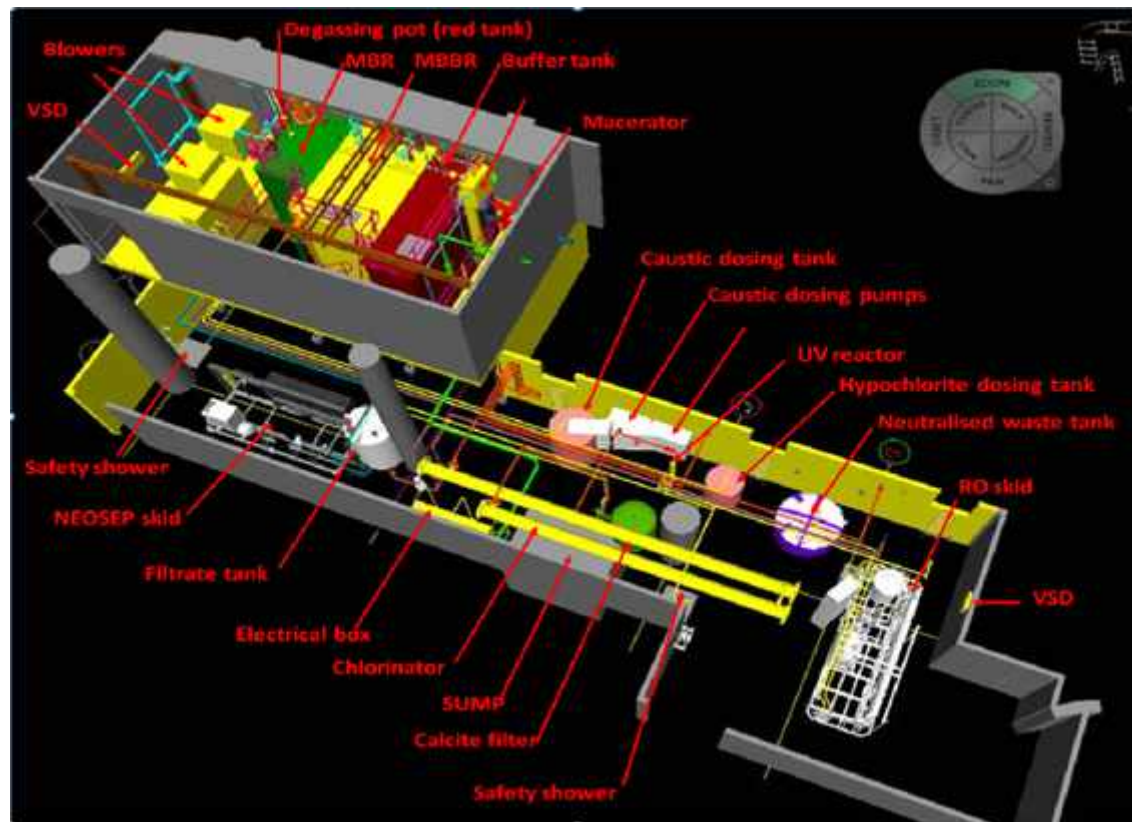

Design challenges... A very small plant room

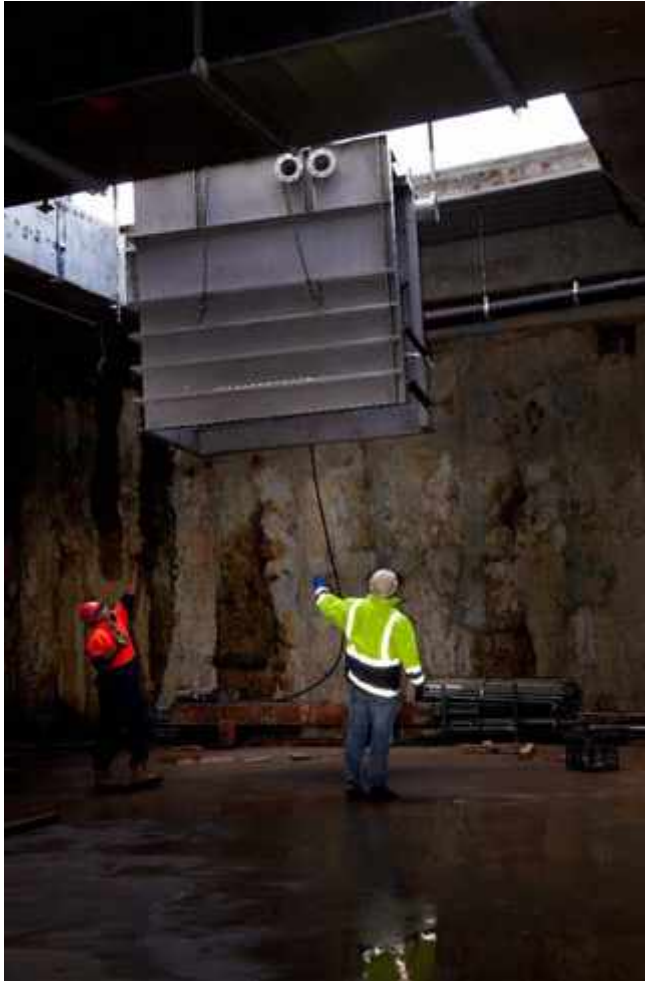

Odour Treatment Solution

- Belt and braces approach to odour treatment for Darl

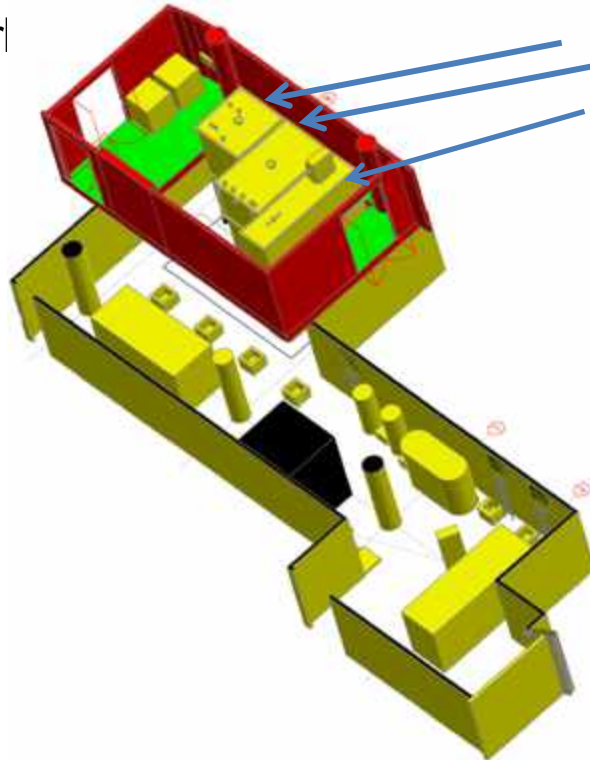

- Buffer tank and Biological tank and pre-treatment Steps are sealed, mechanically vented to an activated carbon filter, then vented to atmosphere at roof level
- 15 room changes per hour are extracted, treated and vented to atmosphere at roof level

Darling Quarter – The process

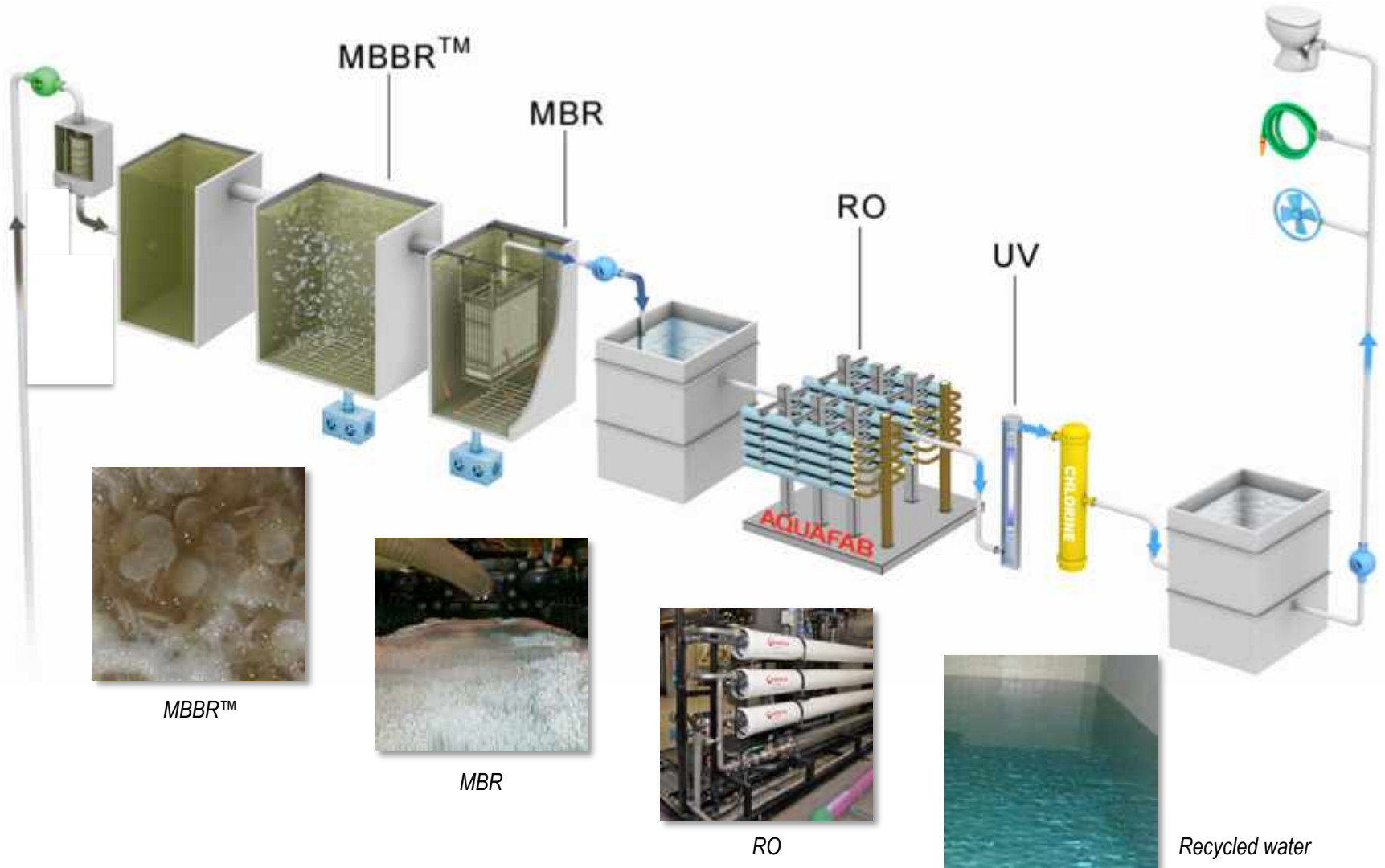

Influent water quality

Parameter	Raw sewage
Oil & Grease (mg/L)	50
Ammonia (mg/L)	45
BOD5 (mg/L)	230
pH	6-9
TDS (mg/L)	550
TSS (mg/L)	370
TN (mg/L)	50
TP (mg/L)	10

Effluent water parameters

Parameters	Darling Quarter – Concentration (mg/L)
Total Suspended Solids (mg/L)	<5
Biochemical Oxygen Demand (mg/L)	<5
pH (pH units)	6-9
Turbidity (NTU)	<0.2 after MBR
E. Coli (CFU/100mL)	<1/100mL
Cl residual (mg/L)	0.2 – 2
Coliphages (pfu/100mL)	<1/100mL
Clostridia (CFU/100mL)	<1/100mL
Total Dissolved Solids (mg/L)	<100* after RO
Validated Virus reduction	6.5 log reduction
Validated Bacteria reduction	5 log reduction
Validated Protozoa reduction	5 log reduction

Energy Optimisation after Start Up

- Identification of the most energy consuming equipment in the process
- Optimization of the process
- Focus on reducing the energy of the 3 highest demand areas

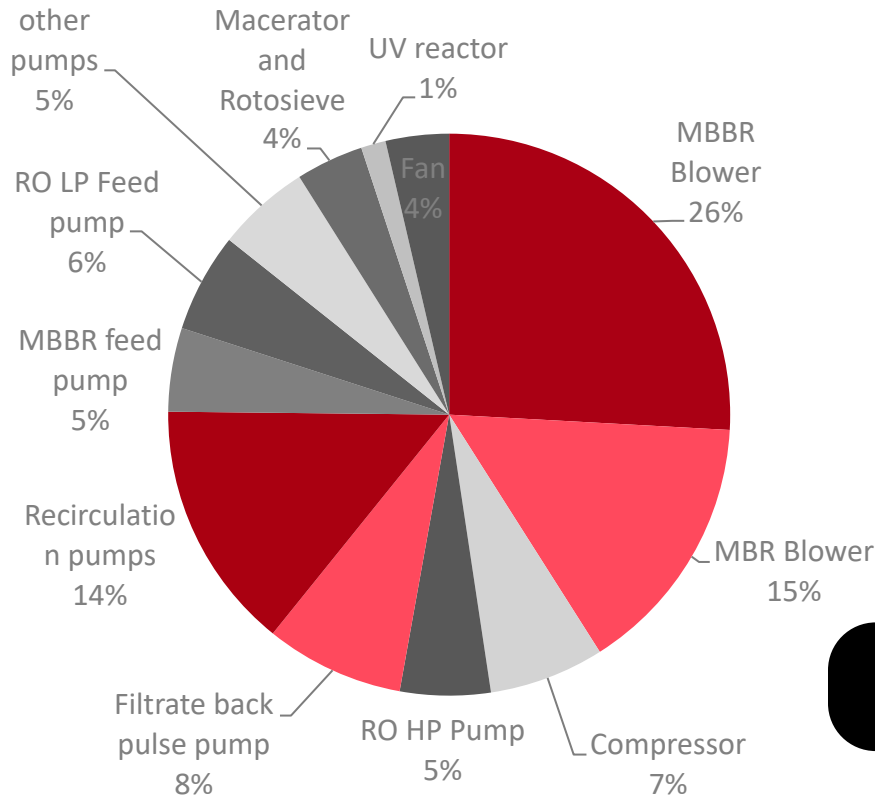

Date	Power consumption [kW /m ³ produced water]
8/12/2012	3.6
31/01/2012	3.4
1/02/2012	3.5
2/02/2012	3.7

Target: 3.5 kW per m³ produced water

Thank you!

michel.danau@veolia.com

WOWproject, winning grondstoffen uit afvalwater
Waterhergebruik in recreatiepark en woonwijk
Enzymatische omzetting cellulose

Cellulose uit rioolwater

Overzicht

Chris Reijken



ENERGIE EN
Grondstoffen
FABRIEK



EEN INITIATIEF VAN
DE NEDERLANDSE
WATERSCHAPPEN

Werkgroep cellulose

WC papier Edet Soft 4 laags

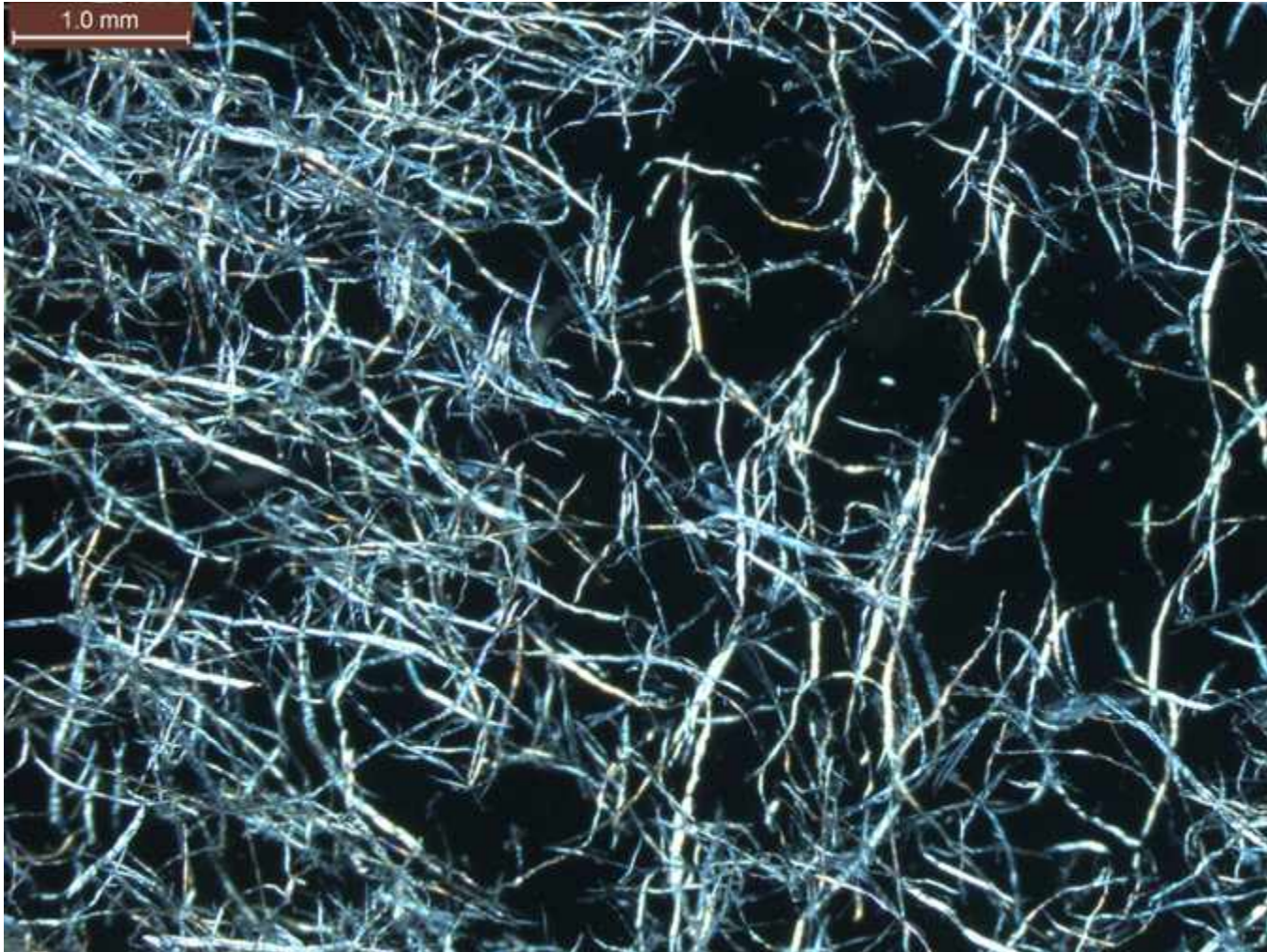

Opties winnen cellulose

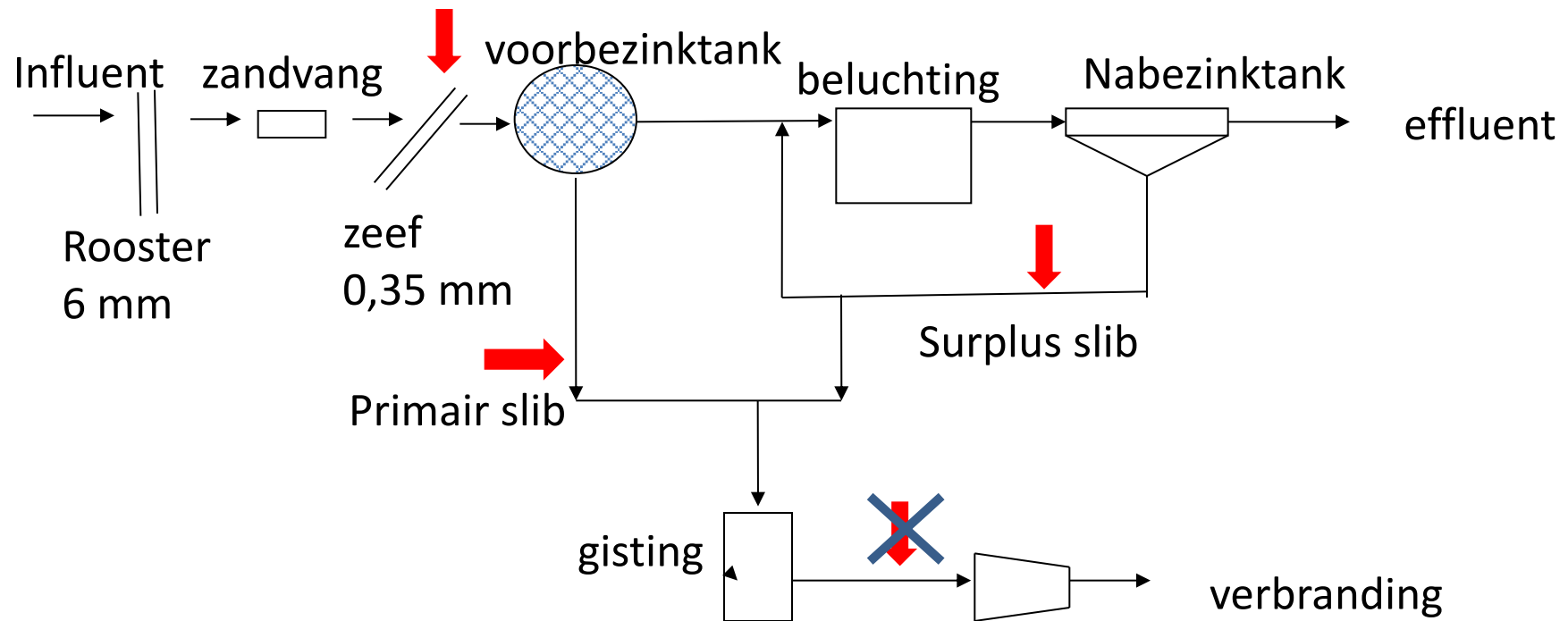

Nederland ca. 100.000 ton/jaar cellulose.

1. Influent 50% cellulose, veel kleinere rwzi's, behandeling van zeefgoed
2. voorbezinktanks 50% cellulose, grotere rwzi's, behandeling van primair slib

Zeefgoed uit influent, 70 %(ods)



Cellulose uit Primair slib, ca 40 %(ods) van PS

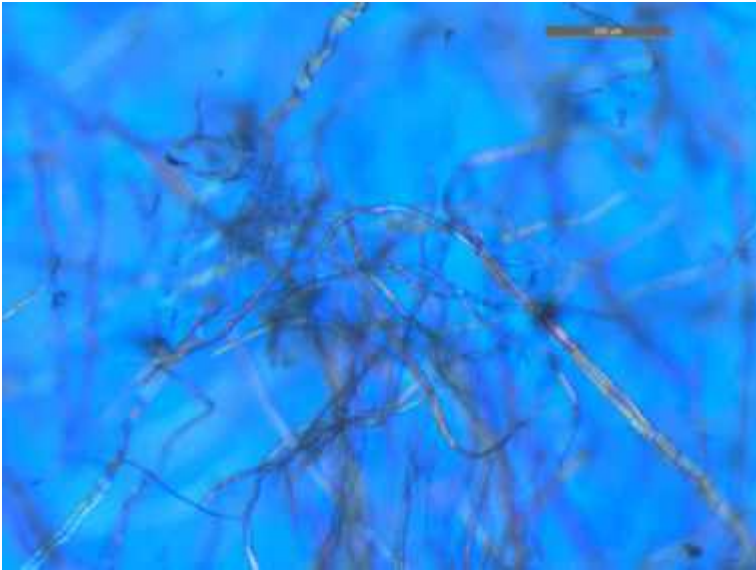

Cellulose in actief slib



Items

1. Interactie cellulose, rwzi waterlijn en slibgisting
2. Hoeveel cellulose is winbaar
3. Kosten winnen cellulose; techniek en schaalgrootte
4. Kosten opschonen zeefgoed of primair slib
5. Kwaliteit vezel, restverontreiniging, afnemers
6. Business case
7. Juridische vraagstukken

Werkgroep cellulose

Geschiedenis; Proefinstallatie MBR, Huber 2002 – 2005 “gewapend” Papier-maché



Proefinstallaties

RWZI Blaricum 2008 - 2009



RWZI Blaricum 2011 - 2014



RWZI Hilversum 2014



ACT proefinstallatie Aarle Rixtel 2014



RWZI Beemster





RWZI Aarle Rixtel





JOUW WC-PAPIER UIT
RIJDL WATER IS OP WEG
NAAR EEN NIEUWE BESTEMMING
WINNEN WAT VAN WAARDE IS. NL

JOUW WC-PAPIER UIT
RIJDL WATER IS OP WEG
NAAR EEN NIEUWE
BESTEMMING



JOUW WC-PAPIER UIT
RIJDL WATER IS OP WEG
NAAR EEN NIEUWE BESTEMMING
WINNEN WAT VAN WAARDE IS. NL

Hoppe
1000
10-11-2018
B-VK

RWZI Ommen



AWZI Schiphol

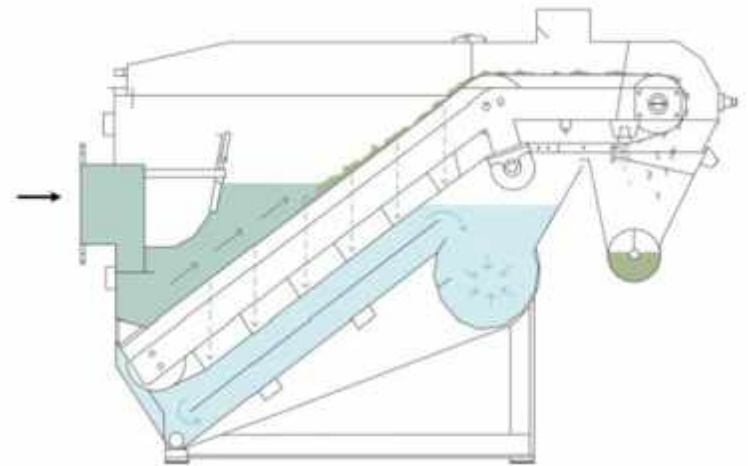

Pilot rwzi Leeuwarden



Fietspaden en wegen



Mycelium



Draad en plaatmateriaal



Enzymatische omzetting

enzymatisch

Invloed temperatuur

Temperature fixed at 50 °C for further tests

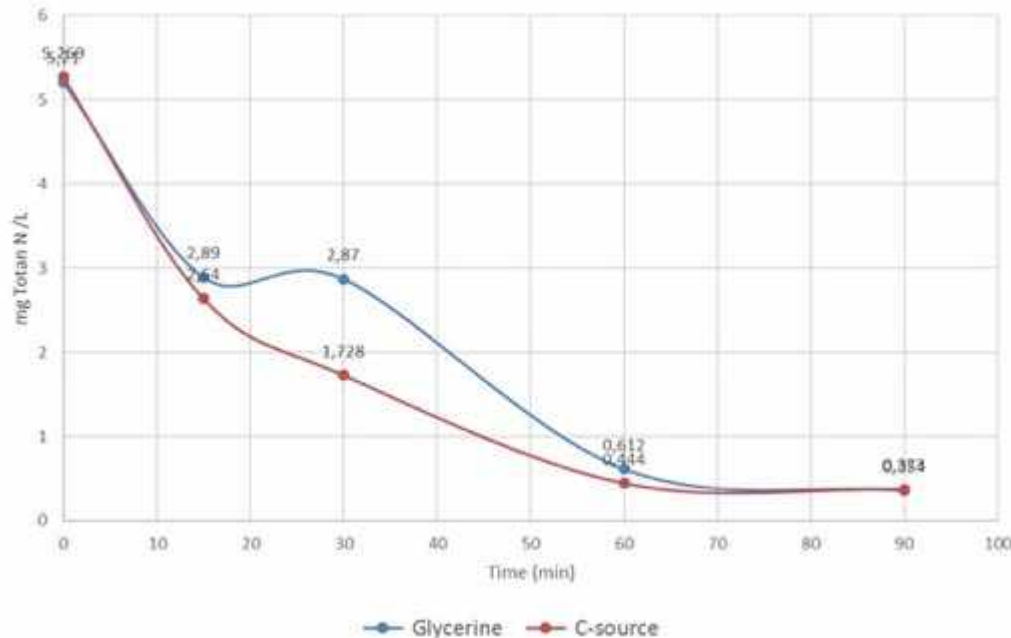
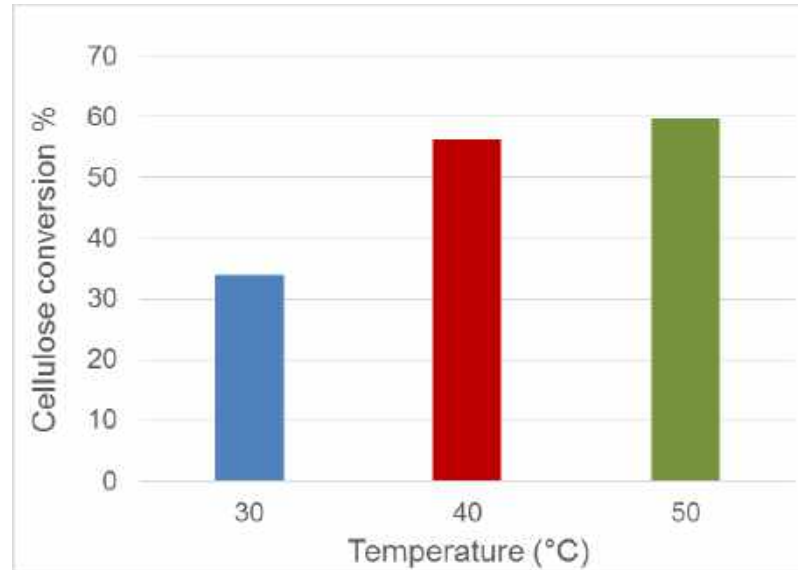

Does it work? Yes it does!

Denitrification test –
comparison purchased
and produced C-source

Roadmap Cellulose

In 2030 zijn alle waterschappen volledig ingericht op hun kerntaak:
 het zelfstandig en kostenneutraal terugwinnen van grondstoffen uit afvalwater, waaronder cellulose.
 De technologie voor het winnen en opschonen van cellulose is volledig geoptimaliseerd. Er is een actieve
 marktvraag naar teruggewonnen cellulose voor economisch aantrekkelijke en duurzame toepassingen.
 Ook de waterschappen en partners in de waterketen gebruiken het eigen teruggewonnen materiaal.
 Het hergebruik van cellulose uit afvalwater is net zo ingeburgerd als het recycleren van glas.



Value

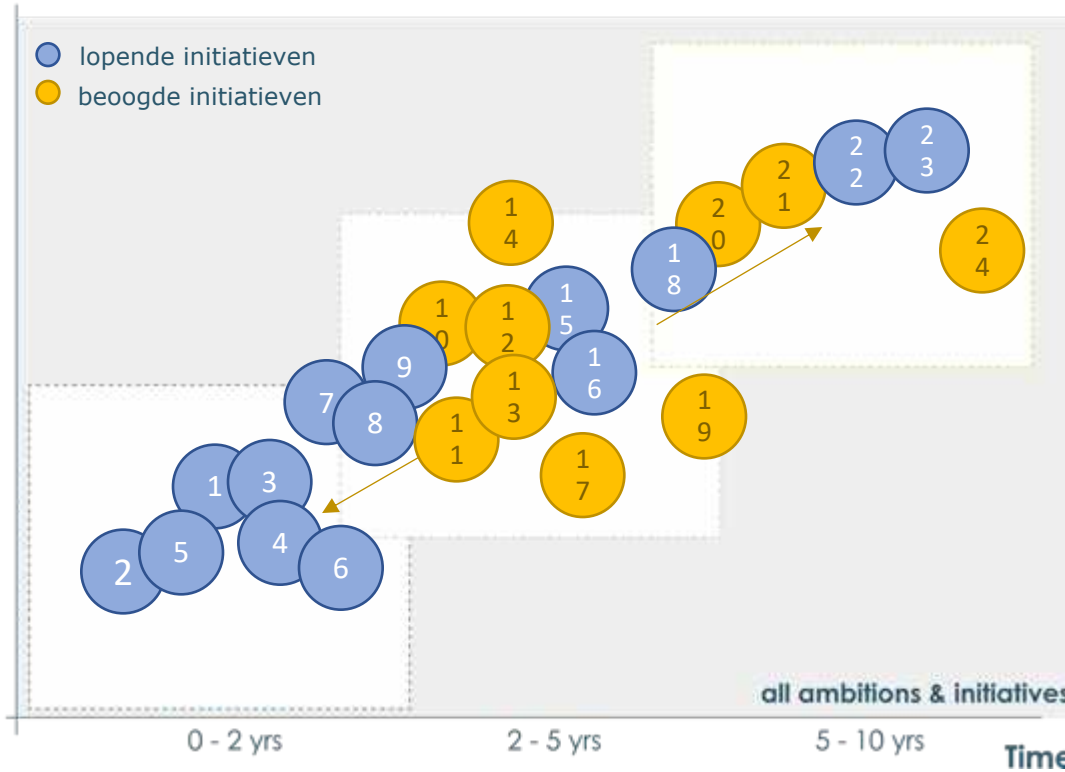

1. Fijnzeven op diverse RWZI's in bedrijf (en optimaliseren)
2. Ontwikkelen afzetketens voor huidig zeefgoed
3. Materiaal ontwikkelen voor toepassing in waterwerk
4. Ecor
5. Lokale vergisting
6. ECN/TNO onderzoek rol cellulose bij ontwikkeling Torwash technologie
7. Cellvation
8. Winning uit primair slib
9. Onderzoek Meri Voigt zeef (betere vezel)
10. Breder verkenning nieuwe technieken gerichte cellulose winning
11. Samenwerking papier industrie
12. Product verbetering uniform, schoon/vies
13. Meer zeefgoed oogsten om opwerkingsinstallatie te realiseren
14. Lobby imago cellulose uit afvalwater
15. CaDos (indikken/ontwateren slib)
16. Winning uit secundair slib
17. (primair slib) opgewerkt uit papier/karton
18. Pyrolyse: zeefgoed naar bio-char (actief koop), bio-oil
19. Colubris
20. Mycelium composiet
21. Vetzuren zeefgoed
22. Cellu2PLA
23. Waste to Aromatics
24. Papierloos toiletgebruik stimuleren (technologie, gedrag)

Factsheet Fijnzeven voor terugwinnen cellulosevezels in influent

1. **Type fijnzeven:**
2. Roterende bandzeven
3. Horizontaal opgestelde trommelfilters
4. Verticaal opgestelde trommelfilters

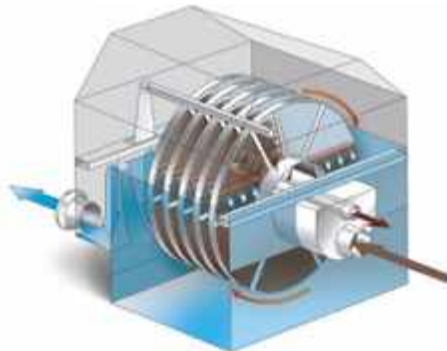

Installaties NL

RWZI Blaricum
RWZI Beemster
RWZI Aarle-Rixtel
RWZI Uithuizermeeden
AWZI Schiphol (vanaf juni 2019)
RWZI Ommen
RWZI Geestmerambacht Cirtec
RWZI Leidsche Rijn (maart 2020)

RWZI Harderwijk?
RWZI Zeewolde?
RWZI ??

W2A, Wascom, Saxion, enzymatisch
Pilot Beemster, hergebruik vezel voor papier en plaatmateriaal
Pilot Ede, actief kool
Verzuren zeefgoed, vetzuren

Veel publicaties en rapporten beschikbaar



WWTP



Q&A